



## FLT FLOOR CONVECTOR WITH FAN

### 24V DC - FLOOR CONVECTORS, DIRECT-CURRENT VOLTAGE

<p><b>FLT10-09</b> 270×90×800-4800 mm Q 75/65/20 °C: 262-3188 W Q 55/45/20 °C: 148-1808 W heating, 2 pipe system page 12</p>	<p><b>FLT20-09</b> 320×90×800-4800 mm Q 75/65/20 °C: 545-6643 W Q 55/45/20 °C: 301-3670 W heating, 2 pipe system page 13</p>	<p><b>FLT10-11</b> 270×115×800-4800 mm Q 75/65/20 °C: 233-2566 W Q 55/45/20 °C: 134-1472 W heating, 2 pipe system page 14</p>	<p><b>FLT20-11</b> 320×115×800-4800 mm Q 75/65/20 °C: 461-5074 W Q 55/45/20 °C: 270-2970 W heating, 2 pipe system page 15</p>	<p><b>FCC2A, FCC 4A</b> 320×134×1200-2800 mm Q 75/65/20 °C: 2001-6003 W Q 55/45/20 °C: 1191-3574 W heating, cooling, 2 and 4 pipe system page 20, 22</p>
--	--	---	---	--

### 12V DC - FLOOR CONVECTORS FOR SWIMMING POOLS

<p><b>FLB20-12</b> 270×125×800-4800 mm Q 75/65/20 °C: 422-4647 W Q 55/45/20 °C: 213-2348 W heating, cooling, 2 pipe system page 28</p>
--

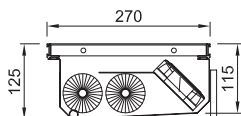

Note: Heat outputs correspond to the middle speed of a fan

### FLOOR CONVECTOR WITH NATURAL CONVECTION

<p><b>FLK10-09</b> 170×90×800-4800 mm Q 75/65/20 °C: 95-945 W Q 55/45/20 °C: 45-446 W heating, 2 pipe system page 34</p>	<p><b>FLK20-09</b> 320×90×800-4800 mm Q 75/65/20 °C: 161-1655 W Q 55/45/20 °C: 76-789 W heating, 2 pipe system page 34</p>	<p><b>FLK30-09</b> 360×90×800-4800 mm Q 75/65/20 °C: 227-2193 W Q 55/45/20 °C: 118-1118 W heating, 2 pipe system page 34</p>	<p><b>FLK40-09</b> 420×90×800-4800 mm Q 75/65/20 °C: 293-2731 W Q 55/45/20 °C: 160-1447 W heating, 2 pipe system page 34</p>	<p><b>FLK10-11</b> 170×115×800-4800 mm Q 75/65/20 °C: 102-1011 W Q 55/45/20 °C: 48-487 W heating, 2 pipe system page 36</p>
<p><b>FLK20-11</b> 320×115×800-4800 mm Q 75/65/20 °C: 174-1798 W Q 55/45/20 °C: 84-859 W heating, 2 pipe system page 36</p>	<p><b>FLK30-11</b> 360×115×800-4800 mm Q 75/65/20 °C: 246-2341 W Q 55/45/20 °C: 118-1118 W heating, 2 pipe system page 36</p>	<p><b>FLK40-11</b> 420×115×800-4800 mm Q 75/65/20 °C: 318-2884 W Q 55/45/20 °C: 152-1377 W heating, 2 pipe system page 36</p>	<p><b>FLK10-14</b> 170×140×800-4800 mm Q 75/65/20 °C: 117-1162 W Q 55/45/20 °C: 55-549 W heating, 2 pipe system page 38</p>	<p><b>FLK20-14</b> 320×140×800-4800 mm Q 75/65/20 °C: 215-2229 W Q 55/45/20 °C: 104-1065 W heating, 2 pipe system page 38</p>
<p><b>FLK30-14</b> 360×140×800-4800 mm Q 75/65/20 °C: 317-3019 W Q 55/45/20 °C: 152-1442 W heating, 2 pipe system page 38</p>	<p><b>FLK40-14</b> 420×140×800-4800 mm Q 75/65/20 °C: 394-3576 W Q 55/45/20 °C: 188-1707 W heating, 2 pipe system page 38</p>	<p><b>FLK20-18</b> 300×180×800-4800 mm Q 75/65/20 °C: 257-2787 W Q 55/45/20 °C: 124-1346 W heating, 2 pipe system page 40</p>	<p><b>FLK30-18</b> 360×180×800-4800 mm Q 75/65/20 °C: 293-3180 W Q 55/45/20 °C: 142-1536 W heating, 2 pipe system page 40</p>	<p><b>FLK20-30</b> 300×300×800-4800 mm Q 75/65/20 °C: 289-3131 W Q 55/45/20 °C: 135-1460 W heating, 2 pipe system page 40</p>
<p><b>FLK30-30</b> 360×300×800-4800 mm Q 75/65/20 °C: 419-4284 W Q 55/45/20 °C: 195-2118 W heating, 2 pipe system page 40</p>				

## STAINLESS TANK

is made of stainless steel DIN 1,4301 (17240), wall thickness 0.8 mm, inner surface treatment by spray painting is also available. The tank containing all the convector functional elements is provided with openings for water inlet/outlet and for electric cables connection (FLT types). A solid peripheral aluminium frame holds a upper grill. The construction stiffened with inner ribs contains levelling screws for height adjusting within the installation.

## HEAT EXCHANGER Cu-Cu, Al-Cu

Heat exchangers Cu-Cu have special wire basket soldered on a copper tube through which the heat carrier circulates. The air flowing among wires distributes the collected heat to the room. The exchanger is provided with an air release valve and connection female thread G1/2". Al-Cu exchangers have aluminium lamellas firmly pressed on a copper tube. It is used at FCC types where the construction is useful for four pipe system.

## UPPER GRILL

is a final visual element of the installed floor convector. The client may have a grid flooring, the long ribs of which follow the window line (material: aluminium, wood, stainless steel) or the client may choose a grill with short perpendicular ribs (material: aluminium). Convectors installed in floating floors can be decked with finishing cover ledges.

## TANGENTIAL FANS

Tangential fans obtain forced air circulation reflected in more effective use of exchanger heating capacity in comparison with natural air circulation (FLT, FCC types). Shields covering the rotating parts of engine prevent accidents, injuries and fan damages. The integrated regulator enables comfortable regulation of the floor convector heating capacity.

## REGULATION

A regulator placed in the convector controls the fan revs and flow rate of the heating medium through exchanger. The regulator follows instructions by wall thermostat installed in the room. Regulation, fans and convector speed control working under safe voltage 24V DC.

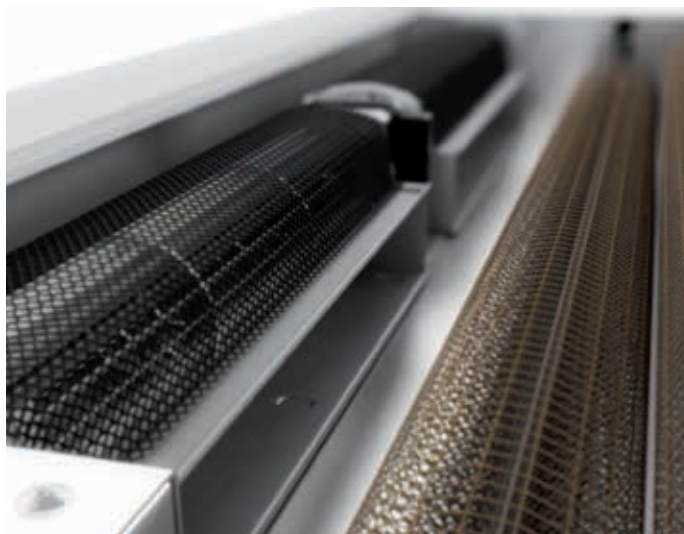

# RUNNING CONDITIONS

- Warm-water heating system with forced circulation
- Heat medium operating temperature, max. 110 °C
- Heat medium operating overpressure, max. 1 MPa
- Electric parts IP 20, operating voltage 24V DC, dry environs
- The convector is construed for ambient temperature between +2 and 40 °C and relative moisture of 20-70 %

# WARRANTY CONDITIONS | EXTRACT

The Seller's warranty covers joint tightness, surface treatment, proclaimed values of heating capacity and loss in pressure relating to heating bodies professionally installed in a closed and sealed system in accordance with applicable standards and decrees, this all under the aspect that the used medium must only serve as the heat carrier. Other usage is excluded.

Electric heating bodies shall be professionally installed in accordance with the applicable standards. FLT, FCC floor convectors with fans, IP 20 – dry environs.

## PERIODS OF RISK

The period of risk is 5 years for joint tightness, 10 years for exchanger and 2 years for electro-installation and stainless steel tank.

# GRILLS



Convactor becomes a functional design element of the interior by correct choose of upper grill suitable material and colour. The grill is fit in a massive aluminium peripheral frame creating an optical boundary between the floor and convactor.

## ALUMINIUM GRILLS

### ROLL-UP GRILLS

The spacing between spring loaded transverse lamellas of aluminium alloy is delimited by residual rollers made of cured plastic. The lamellas have anodized and tinted surface. Any RAL shade may be reached by powder colour coating.

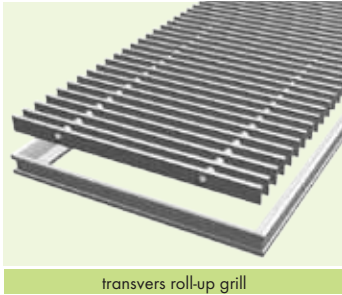

Grill supply is included in price, RAL shades to order.

### LINEAR GRILLS

Lengthwise perforated aluminium lamellas are linked by carrying steel bar. Residual rollers of cured plastic delimitate the spacing.

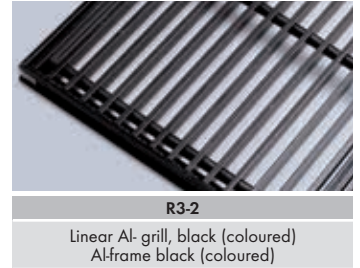
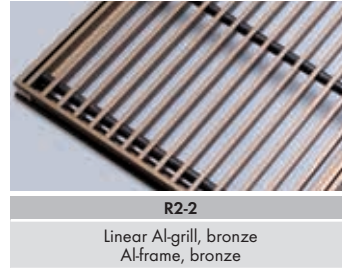
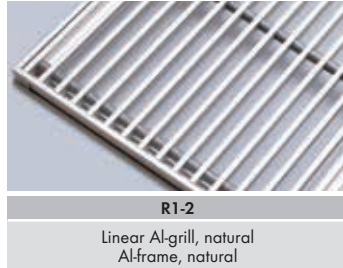

Grill supply is included in price, RAL shades to order.

## WOODEN GRILLS

### ROLL-UP GRILLS

The spacing between spring loaded oak or beech lamellas is delimited by residual rollers made of cured plastic. The surface is raw or stained.

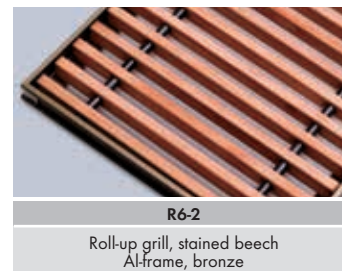
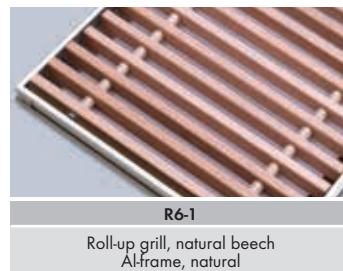

Grill supply is included in price.

## STAINLESS STEEL GRILL

### TRANSVERSE GRILL

Stainless steel rectangular profiles are linked by steel drawbars. The spacing of lamellas is delimited by residual metal rollers. A fix non-rolling grill.



A grill available to order, calculation as per the convactor type.







## PARAMETERS

<b>Convector</b>	Width	270 mm
	Height	90 mm
	Length	800-4800 mm in step 400 mm
	Height adjusting	0-35 mm
	Stainless trough width	250
	Grill type	cross / linear
<b>Exchanger</b>	Width	1 × Ø 65 mm
	Height	
	Finned length	L-380 mm
	Heat medium connection	2 × G1/2" female thread
	Max. working temperature	110 °C
	Max. working overpressure	1 MPa
<b>Fan</b>	Rotor diameter	Ø 40 mm
	Operating voltage	<b>Safe voltage 24V DC</b>
	Ingress protection	IP20
	Regulation	control voltage <b>0-10V</b> (regulation SR201, ...)
<b>Operating conditions</b>	Ambient temperature	+2 to +40 °C
	Relative humidity	20-70%

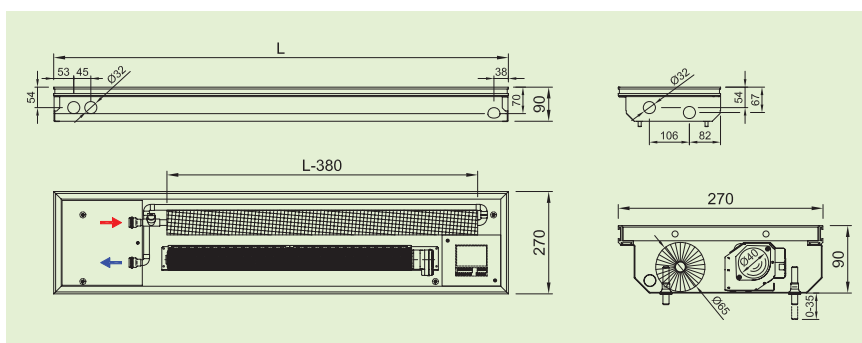

	SPEED	LENGTH [mm]										
		800	1200	1600	2000	2400	2800	3200	3600	4000	4400	4800
<b>ACOUSTIC PRESSURE</b> L <sub>pAmax</sub> [dB(A)]	1	22	24	24	25	25	25	25	25	26	26	26
	2	24	25	27	28	29	31	31	31	31	31	31
	3	30	30	33	34	37	39	39	39	39	39	40
<b>AIR VOLUME</b> [m³/h]	1	27	55	82	109	137	164	191	219	246	273	301
	2	36	65	92	130	184	196	250	276	315	369	380
	3	50	103	140	207	280	310	383	419	486	559	590

Code example	<b>FLT10-09200-NR126</b>	Floor convector FLT10-09, H=90 mm, W=270 mm, L=2000 mm, stainless steel trough, Al natur frame, Al natur linear grill, installed regulation SR201, convector 24V DC
--------------	--------------------------	---

Ordering, see the page 44

## SPECIFICATIONS

- Residence, luxury villas, houses, office buildings
- Forced convection by tangential fans
- High heating output
- Low power consumption
- Safe voltage 24V DC
- Easy control
- Cu-Cu heat exchanger
- Mechanical resistance of the heat exchanger
- Easy cleaning - hygiene
- Smooth running
- Using in dry ambience

## HEATING OUTPUT

### Q [W] 90/70/20 °C

SPEED	0	1	2	3
rpm	0	576	762	1057
LENGTH [mm]	HEATING OUTPUT [W]			
800	70	268	320	393
1200	136	536	640	786
1600	202	804	961	1179
2000	268	1073	1281	1572
2400	334	1609	1921	2358
2800	401	1670	1982	2419
3200	467	2145	2561	3144
3600	533	2413	2882	3537
4000	599	2681	3202	3930
4400	666	3218	3842	4716
4800	732	3279	3904	4778

### Qn [W] 75/65/20 °C

SPEED	0	1	2	3
rpm	0	576	762	1057
LENGTH [mm]	HEATING OUTPUT [W]			
800	53	219	262	321
1200	104	438	523	642
1600	155	657	785	963
2000	206	876	1046	1284
2400	257	1314	1569	1926
2800	308	1364	1619	1976
3200	359	1752	2092	2568
3600	410	1971	2354	2889
4000	461	2190	2615	3210
4400	512	2628	3138	3852
4800	563	2678	3188	3902

### Q [W] 70/55/20 °C

SPEED	0	1	2	3
rpm	0	576	762	1057
LENGTH [mm]	HEATING OUTPUT [W]			
800	42	183	218	268
1200	83	366	437	536
1600	123	549	655	804
2000	163	731	873	1072
2400	203	1097	1310	1608
2800	244	1139	1351	1649
3200	284	1463	1747	2144
3600	324	1646	1965	2412
4000	364	1828	2183	2680
4400	405	2194	2620	3216
4800	445	2236	2662	3258

### Q [W] 55/45/20 °C

SPEED	0	1	2	3
rpm	0	576	762	1057
LENGTH [mm]	HEATING OUTPUT [W]			
800	26	124	148	182
1200	50	248	297	364
1600	74	373	445	546
2000	99	497	593	728
2400	123	745	890	1092
2800	147	773	918	1120
3200	172	994	1186	1456
3600	196	1118	1335	1638
4000	220	1242	1483	1820
4400	245	1490	1780	2185
4800	269	1519	1808	2213



## SPECIFICATIONS

- Residence, luxury villas, houses, office buildings
- Forced convection by tangential fans
- High heating output
- Low power consumption
- Safe voltage 24V DC
- Easy control
- Cu-Cu heat exchanger
- Mechanical resistance of the heat exchanger
- Easy cleaning - hygiene
- Smooth running
- Using in dry ambience

## HEATING OUTPUT

### Q [W] 90/70/20 °C

SPEED	0	1	2	3
rpm	0	576	762	1057
LENGTH [mm]	HEATING OUTPUT [W]			
800	170	661	673	687
1200	311	1323	1346	1374
1600	453	1984	2019	2060
2000	594	2646	2692	2747
2400	735	3969	4037	4121
2800	877	4103	4172	4255
3200	1018	5292	5383	5494
3600	1160	5953	6056	6181
4000	1301	6615	6729	6868
4400	1442	7938	8075	8242
4800	1584	8072	8209	8376

### Qn [W] 75/65/20 °C

SPEED	0	1	2	3
rpm	0	576	762	1057
LENGTH [mm]	HEATING OUTPUT [W]			
800	130	535	545	556
1200	239	1071	1089	1112
1600	348	1606	1634	1667
2000	456	2141	2178	2223
2400	565	3212	3267	3335
2800	674	3320	3376	3443
3200	783	4282	4356	4446
3600	891	4817	4901	5002
4000	1000	5353	5445	5558
4400	1109	6423	6534	6669
4800	1217	6532	6643	6778

### Q [W] 70/55/20 °C

SPEED	0	1	2	3
rpm	0	576	762	1057
LENGTH [mm]	HEATING OUTPUT [W]			
800	103	443	451	460
1200	189	886	902	920
1600	275	1330	1353	1380
2000	361	1773	1803	1841
2400	447	2659	2705	2761
2800	533	2749	2795	2851
3200	619	3546	3607	3681
3600	705	3989	4058	4141
4000	791	4432	4509	4602
4400	877	5318	5410	5522
4800	963	5408	5500	5612

### Q [W] 55/45/20 °C

SPEED	0	1	2	3
rpm	0	576	762	1057
LENGTH [mm]	HEATING OUTPUT [W]			
800	62	296	301	307
1200	114	591	602	614
1600	166	887	903	921
2000	218	1183	1203	1228
2400	270	1774	1805	1842
2800	322	1835	1865	1903
3200	374	2366	2407	2457
3600	426	2662	2708	2764
4000	478	2957	3009	3071
4400	530	3549	3610	3685
4800	582	3609	3670	3745

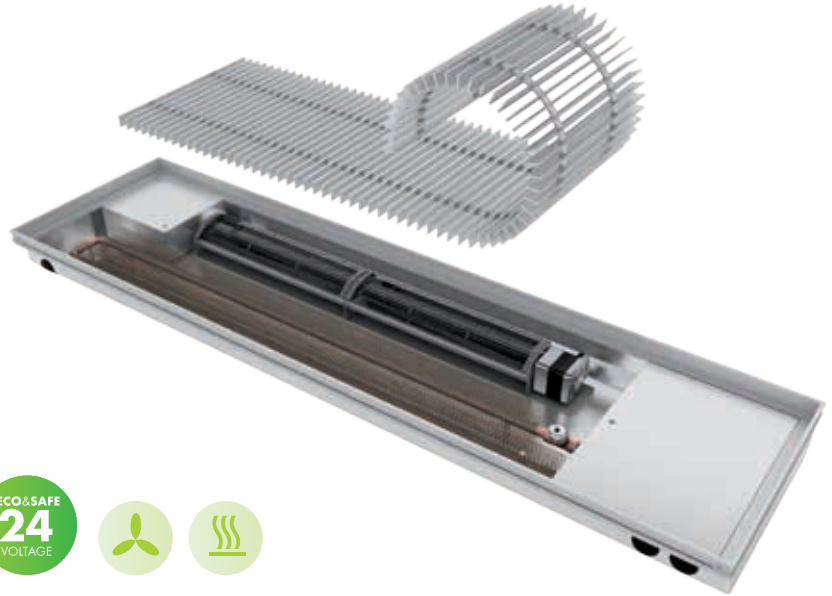

## PARAMETERS

<b>Convector</b>	Width	320 mm
	Height	90 mm
	Length	800–4800 mm in step 400 mm
	Height adjusting	0–35 mm
	Stainless trough width	300 mm
	Grill type	cross / linear
	Grill material	anodized aluminium, wood, stainless steel
<b>Exchanger</b>	Width	2 × Ø 65 mm
	Height	
	Finned length	L-320 mm
	Heat medium connection	2 × G1/2" female thread
	Max. working temperature	110 °C
	Max. working overpressure	1 MPa
<b>Fan</b>	Rotor diameter	Ø 40 mm
	Operating voltage	Safe voltage 24V DC
	Ingress protection	IP20
	Regulation	control voltage 0–10V (regulation SR201, ...)
<b>Operating conditions</b>	Ambient temperature	+2 to +40 °C
	Relative humidity	20–70%

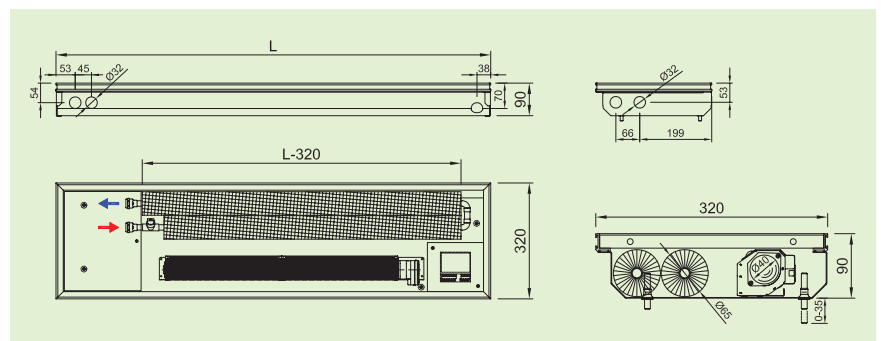

	SPEED	LENGTH [mm]										
		800	1200	1600	2000	2400	2800	3200	3600	4000	4400	4800
<b>ACOUSTIC PRESSURE</b> LpAmax [dB(A)]	1	22	24	24	25	25	25	25	25	26	26	26
	2	24	25	27	28	29	31	31	31	31	31	31
	3	30	30	33	34	37	39	39	39	39	39	40
<b>AIR VOLUME</b> [m³/h]	1	26	53	80	107	134	160	187	214	240	267	294
	2	35	64	90	128	180	191	244	270	308	361	372
	3	49	101	137	202	273	303	375	410	476	547	577

<b>Code example</b>	<b>FLT20-09120-NR116</b>	Floor convector FLT20-09, H=90 mm, W=320 mm, L=1200 mm, stainless steel trough, Al natur frame, Al natur cross roll-up grill, installed regulation SR201, convector 24V DC
---------------------	--------------------------	--

Ordering, see the page 44



## PARAMETERS

<b>Convector</b>	Width	270 mm
	Height	115 mm
	Length	800-4800 mm in step 400 mm
	Height adjusting	0-35 mm
	Stainless trough width	250 mm
	Grill type	cross / linear
	Grill material	anodized aluminium, wood, stainless steel
<b>Exchanger</b>	Width	1 x Ø 65 mm
	Height	
	Finned length	L-440 mm
	Heat medium connection	2 x G1/2" female thread
	Max. working temperature	110 °C
	Max. working overpressure	1 MPa
<b>Fan</b>	Rotor diameter	Ø 60 mm
	Operating voltage	Safe voltage 24V DC
	Ingress protection	IP20
	Regulation	control voltage 0-10V (regulation SR203, ...)
<b>Operating conditions</b>	Ambient temperature	+2 to +40 °C
	Relative humidity	20-70%

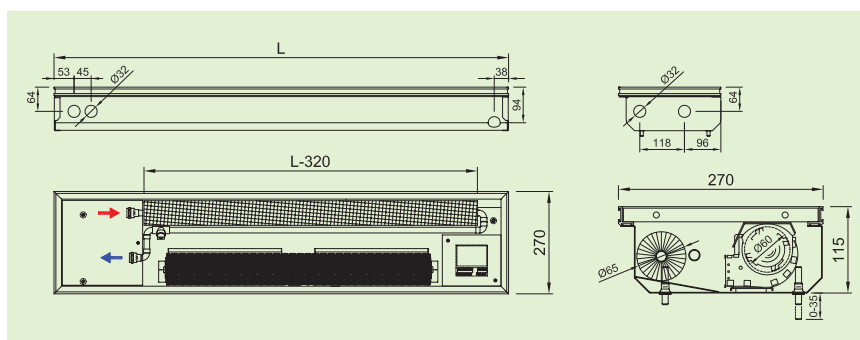

	SPEED	LENGTH [mm]										
		800	1200	1600	2000	2400	2800	3200	3600	4000	4400	4800
<b>ACOUSTIC PRESSURE</b> L <sub>p,Amx</sub> [dB(A)]	1	19	21	23	23	23	24	24	24	24	25	25
	2	26	27	28	28	30	31	32	32	33	33	33
	3	35	35	36	37	39	40	40	40	40	40	41
<b>AIR VOLUME</b> [m³/h]	1	28	56	84	113	141	169	197	225	253	281	309
	2	37	80	117	159	197	239	277	319	357	400	437
	3	51	117	168	234	285	351	402	468	519	585	636

<b>Code example</b>	<b>FLT10-11080-NR215</b>	Floor convector FLT10-11, H=115 mm, W=270 mm, L=800 mm, stainless steel trough, Al bronze frame, Al bronze cross roll-up grill, without regulation, convector 24V DC
---------------------	--------------------------	--

Ordering, see the page 44

## SPECIFICATIONS

- Residence, luxury villas, houses, office buildings
- Forced convection by tangential fans
- High heating output
- Low power consumption
- Safe voltage 24V DC
- Easy control
- Cu-Cu heat exchanger
- Mechanical resistance of the heat exchanger
- Easy cleaning - hygiene
- Smooth running
- Using in dry ambience

## HEATING OUTPUT

### Q [W] 90/70/20 °C

SPEED	0	1	2	3
rpm	0	465	582	756
LENGTH [mm]	HEATING OUTPUT [W]			
800	100	233	284	354
1200	183	465	569	708
1600	267	698	853	1062
2000	350	930	1138	1416
2400	433	1163	1422	1769
2800	517	1395	1706	2123
3200	600	1628	1991	2477
3600	683	1861	2275	2831
4000	767	2093	2559	3185
4400	850	2326	2844	3539
4800	933	2558	3128	3893

### Qn [W] 75/65/20 °C

SPEED	0	1	2	3
rpm	0	465	582	756
LENGTH [mm]	HEATING OUTPUT [W]			
800	77	191	233	290
1200	141	382	467	581
1600	205	572	700	871
2000	269	763	933	1161
2400	333	954	1166	1451
2800	397	1145	1400	1742
3200	461	1335	1633	2032
3600	525	1526	1866	2322
4000	589	1717	2099	2612
4400	653	1908	2333	2903
4800	717	2098	2566	3193

### Q [W] 70/55/20 °C

SPEED	0	1	2	3
rpm	0	465	582	756
LENGTH [mm]	HEATING OUTPUT [W]			
800	61	160	195	243
1200	111	320	391	486
1600	162	480	586	730
2000	213	639	782	973
2400	263	799	977	1216
2800	314	959	1173	1459
3200	365	1119	1368	1703
3600	415	1279	1564	1946
4000	466	1439	1759	2189
4400	517	1599	1955	2432
4800	567	1758	2150	2676

### Q [W] 55/45/20 °C

SPEED	0	1	2	3
rpm	0	465	582	756
LENGTH [mm]	HEATING OUTPUT [W]			
800	37	109	134	167
1200	67	219	268	333
1600	98	328	402	500
2000	129	438	535	666
2400	159	547	669	833
2800	190	657	803	999
3200	221	766	937	1166
3600	251	876	1071	1333
4000	282	985	1205	1499
4400	312	1095	1339	1666
4800	343	1204	1472	1832



## SPECIFICATIONS

- Residence, luxury villas, houses, office buildings
- Forced convection by tangential fans
- High heating output
- Low power consumption
- Safe voltage 24V DC
- Easy control
- Cu-Cu heat exchanger
- Mechanical resistance of the heat exchanger
- Easy cleaning - hygiene
- Smooth running
- Using in dry ambience

## HEATING OUTPUT

### Q [W] 90/70/20 °C

SPEED	0	1	2	3
rpm	0	465	582	756
LENGTH [mm]	HEATING OUTPUT [W]			
800	185	478	558	693
1200	339	956	1117	1387
1600	493	1435	1675	2080
2000	647	1913	2234	2774
2400	800	2391	2792	3467
2800	954	2869	3350	4160
3200	1108	3347	3909	4854
3600	1262	3826	4467	5547
4000	1416	4304	5026	6240
4400	1570	4782	5584	6934
4800	1724	5260	6142	7627

### Qn [W] 75/65/20 °C

SPEED	0	1	2	3
rpm	0	465	582	756
LENGTH [mm]	HEATING OUTPUT [W]			
800	142	395	461	573
1200	260	790	923	1146
1600	379	1185	1384	1718
2000	497	1580	1845	2291
2400	615	1975	2306	2864
2800	734	2370	2768	3437
3200	852	2765	3229	4009
3600	970	3160	3690	4582
4000	1088	3555	4151	5155
4400	1207	3950	4613	5728
4800	1325	4345	5074	6300

### Q [W] 70/55/20 °C

SPEED	0	1	2	3
rpm	0	465	582	756
LENGTH [mm]	HEATING OUTPUT [W]			
800	112	333	389	483
1200	206	666	778	966
1600	299	999	1167	1449
2000	393	1332	1556	1932
2400	487	1666	1945	2415
2800	580	1999	2334	2898
3200	674	2332	2723	3381
3600	767	2665	3112	3864
4000	861	2998	3501	4347
4400	954	3331	3890	4830
4800	1048	3664	4279	5313

### Q [W] 55/45/20 °C

SPEED	0	1	2	3
rpm	0	465	582	756
LENGTH [mm]	HEATING OUTPUT [W]			
800	68	231	270	335
1200	125	462	540	671
1600	181	694	810	1006
2000	238	925	1080	1341
2400	294	1156	1350	1676
2800	351	1387	1620	2012
3200	407	1619	1890	2347
3600	464	1850	2160	2682
4000	521	2081	2430	3017
4400	577	2312	2700	3353
4800	634	2543	2970	3688



## PARAMETERS

<b>Convector</b>	Width	320 mm
	Height	115 mm
	Length	800-4800 mm in step 400 mm
	Height adjusting	0-35 mm
	Stainless trough width	300 mm
	Grill type	cross / linear
<b>Exchanger</b>	Width	2 × Ø 65 mm
	Height	L-320 mm
	Finned length	L-320 mm
	Heat medium connection	2 × G1/2" female thread
	Max. working temperature	110 °C
	Max. working overpressure	1 MPa
<b>Fan</b>	Rotor diameter	Ø 60 mm
	Operating voltage	Safe voltage 24V DC
	Ingress protection	IP20
	Regulation	control voltage 0-10V (regulation SR203, ...)
<b>Operating conditions</b>	Ambient temperature	+2 to +40 °C
	Relative humidity	20-70%

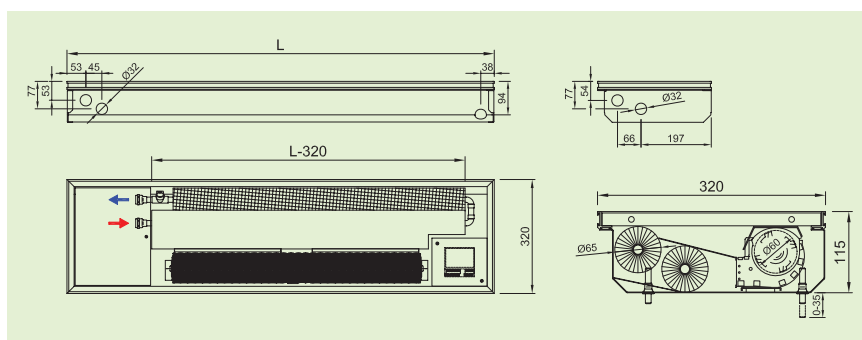

	SPEED	LENGTH [mm]										
		800	1200	1600	2000	2400	2800	3200	3600	4000	4400	4800
<b>ACOUSTIC PRESSURE</b> LpAmax [dB(A)]	1	19	21	23	23	23	24	24	24	24	25	25
	2	26	27	28	28	30	31	32	32	33	33	33
	3	35	35	36	37	39	40	40	40	40	40	41
<b>AIR VOLUME</b> [m³/h]	1	27	56	83	112	139	167	195	223	251	279	307
	2	37	79	116	158	195	237	275	316	354	396	433
	3	51	116	167	232	283	348	398	464	514	580	630

<b>Code example</b>	<b>FLT20-11320-NR126</b>	Floor convector FLT20-11, H=115 mm, W=320 mm, L=3200 mm, stainless steel trough, Al natur frame, Al natur linear grill, installed regulation SR203, convector 24V DC
---------------------	--------------------------	--

Ordering, see the page 44





## PARAMETERS

<b>Convector</b>	Width	320 mm
	Height	134 mm
	Length	1200-2800 mm in step 400 mm
	Height adjusting	0-35 mm
	Stainless trough width	280 mm
	Grill type	cross / linear
	Grill material	anodized aluminium, wood, stainless steel
<b>Exchanger</b>	Width	100 mm
	Height	65 mm
	Finned length	L-465 mm
	Heat medium connection	2 x G1/2" female thread (2 pipe system)
	Max. working temperature	110 °C
<b>Fan</b>	Max. working overpressure	1 MPa
	Rotor diameter	∅ 60 mm
	Operating voltage	input to convector 230V AC, fans 24V DC
	Ingress protection	IP20
<b>Operating conditions</b>	Regulation	control voltage 0-10V (installed regulation)
	Ambient temperature	+2 to +40 °C
	Relative humidity	20-70 %

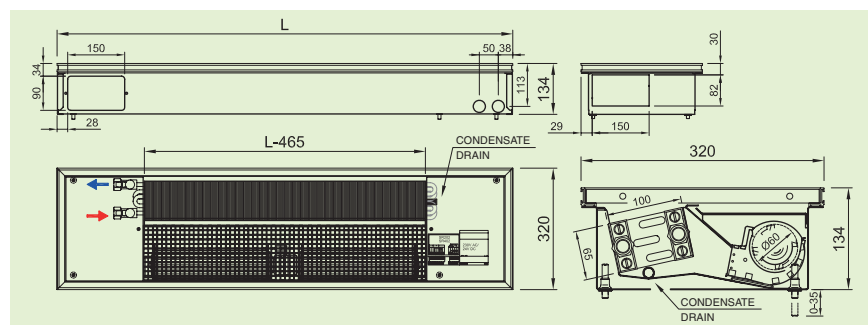

	SPEED	LENGTH [mm]				
		1200	1600	2000	2400	2800
<b>ACOUSTIC PRESSURE</b> LpAmax [dB(A)]	1	<20	<20	<20	<20	<20
	2	20	22	25	25	25
	3	30	32	34	35	36
	4	40	42	44	45	46
	5	48	49	51	52	53
<b>AIR VOLUME</b> [m³/h]	1	47	66	100	114	147
	2	89	123	179	195	266
	3	134	191	266	336	394
	4	179	255	356	449	526
	5	212	302	422	532	624

**Code example** FCC2A-13200-NR127 Floor convector FCC2A-13, H=134 mm, W=320 mm, L=2000 mm, stainless steel trough, Al natur frame, Al natur linear grill, installed regulation, convector with fans 24V DC

Regulation is always a part of the convector, black covers of water and electricity. Ordering, see the page 44

## SPECIFICATION

- Fully glazed rooms with big heat gains
- Flats, villas, residences, hotels
- High heat output
- Optimum after-cooling output
- Convection with tangential fans
- Silent operation
- Dry environment
- Safety voltage 24 V
- Low consumption of electric energy
- Easy operation

## HEATING OUTPUT

### Q [W] 90/70/20 °C

Speed level	Minimal	Standard level			Maximal
SPEED	1	2	3	4	5
LENGTH [mm]	HEATING OUTPUT Q <sub>h</sub> [W]				
1200	645	1466	<b>2408</b>	3115	3591
1600	967	2198	<b>3612</b>	4673	5386
2000	1290	2931	<b>4816</b>	6231	7181
2400	1612	3664	<b>6019</b>	7788	8977
2800	1935	4397	<b>7223</b>	9346	10772

### Qn [W] 75/65/20 °C

Speed level	Minimal	Standard level			Maximal
SPEED	1	2	3	4	5
LENGTH [mm]	HEATING OUTPUT Q <sub>h</sub> [W]				
1200	536	1218	<b>2001</b>	2589	2984
1600	804	1827	<b>3002</b>	3884	4476
2000	1072	2436	<b>4002</b>	5178	5968
2400	1340	3045	<b>5003</b>	6473	7460
2800	1608	3654	<b>6003</b>	7767	8952

### Q [W] 70/55/20 °C

Speed level	Minimal	Standard level			Maximal
SPEED	1	2	3	4	5
LENGTH [mm]	HEATING OUTPUT Q <sub>h</sub> [W]				
1200	454	1033	<b>1697</b>	2195	2530
1600	682	1549	<b>2545</b>	3293	3795
2000	909	2066	<b>3393</b>	4391	5060
2400	1136	2582	<b>4242</b>	5488	6326
2800	1363	3098	<b>5090</b>	6586	7591

### Q [W] 55/45/20 °C

Speed level	Minimal	Standard level			Maximal
SPEED	1	2	3	4	5
LENGTH [mm]	HEATING OUTPUT Q <sub>h</sub> [W]				
1200	319	725	<b>1191</b>	1542	1777
1600	479	1088	<b>1787</b>	2312	2665
2000	638	1450	<b>2383</b>	3083	3553
2400	798	1813	<b>2979</b>	3854	4442
2800	957	2176	<b>3574</b>	4625	5330





### Q [W] 6/12 °C

Speed level			Minimal		Standard level						Maximal	
SPEED			1		2		3		4		5	
LENGTH [mm]	Ti [°C]	r.v. [%]	COOLING OUTPUT [W]									
			Qk[W]	Qs[W]	Qk[W]	Qs[W]	Qk[W]	Qs[W]	Qk[W]	Qs[W]	Qk[W]	Qs[W]
1200	30	45	183	117	547	356	1119	740	1300	880	1520	1047
	28	50	170	106	508	322	1038	669	1206	794	1410	943
	26	50	140	95	415	287	<b>847</b>	<b>598</b>	985	712	1148	847
	24	50	110	83	326	252	661	524	773	627	898	747
1600	30	45	274	175	820	534	1678	1110	1950	1320	2280	1571
	28	50	256	160	762	483	1557	1003	1810	1191	2115	1415
	26	50	210	143	623	431	<b>1270</b>	<b>896</b>	1478	1068	1722	1271
	24	50	165	124	489	377	992	786	1159	941	1346	1120
2000	30	45	365	233	1093	711	2238	1481	2600	1761	3040	2095
	28	50	341	213	1016	644	2076	1338	2413	1587	2820	1886
	26	50	280	190	831	574	<b>1694</b>	<b>1195</b>	1970	1424	2296	1694
	24	50	220	166	652	503	1323	1049	1545	1255	1795	1493
2400	30	45	456	292	1366	889	2797	1851	3249	2201	3800	2619
	28	50	426	266	1270	805	2595	1672	3016	1984	3525	2358
	26	50	351	238	1039	718	<b>2117</b>	<b>1494</b>	2463	1780	2870	2118
	24	50	275	207	814	629	1653	1311	1931	1568	2244	1867
2800	30	45	548	350	1640	1067	3357	2221	3899	2641	4560	3142
	28	50	511	319	1524	966	3114	2007	3619	2381	4230	2829
	26	50	421	285	1246	862	<b>2541</b>	<b>1793</b>	2956	2136	3444	2542
	24	50	330	248	977	755	1984	1573	2318	1882	2693	2240

### Q [W] 8/14 °C

Speed level			Minimal		Standard level						Maximal	
SPEED			1		2		3		4		5	
LENGTH [mm]	Ti [°C]	r.v. [%]	COOLING OUTPUT [W]									
			Qk[W]	Qs[W]	Qk[W]	Qs[W]	Qk[W]	Qs[W]	Qk[W]	Qs[W]	Qk[W]	Qs[W]
1200	30	45	155	104	461	318	939	664	1094	796	1275	948
	28	50	142	93	421	283	857	591	1000	709	1163	842
	26	50	111	82	325	248	<b>660</b>	<b>519</b>	774	624	898	745
	24	50	78	69	229	209	465	441	554	537	678	678
1600	30	45	233	157	691	477	1409	996	1641	1193	1913	1422
	28	50	213	140	632	425	1286	886	1499	1064	1745	1264
	26	50	167	123	487	372	<b>991</b>	<b>778</b>	1162	937	1346	1117
	24	50	117	103	344	314	698	662	831	805	1018	1018
2000	30	45	311	209	921	636	1878	1328	2188	1591	2550	1896
	28	50	284	186	842	567	1715	1182	1999	1418	2326	1685
	26	50	222	164	650	495	<b>1321</b>	<b>1037</b>	1549	1249	1795	1490
	24	50	156	137	459	418	931	883	1108	1074	1357	1357
2400	30	45	388	261	1152	795	2348	1660	2735	1989	3188	2369
	28	50	355	233	1053	708	2143	1477	2499	1773	2908	2106
	26	50	278	205	812	619	<b>1651</b>	<b>1296</b>	1936	1561	2244	1862
	24	50	195	172	574	523	1163	1104	1385	1342	1696	1696
2800	30	45	466	313	1382	954	2817	1992	3282	2387	3825	2843
	28	50	426	280	1264	850	2572	1773	2999	2127	3489	2527
	26	50	333	246	974	743	<b>1981</b>	<b>1556</b>	2323	1873	2693	2234
	24	50	234	206	688	627	1396	1324	1662	1611	2035	2035

### Q [W] 12/16 °C

Speed level			Minimal		Standard level						Maximal	
SPEED			1		2		3		4		5	
LENGTH [mm]	Ti [°C]	r.v. [%]	COOLING OUTPUT [W]									
			Qk[W]	Qs[W]	Qk[W]	Qs[W]	Qk[W]	Qs[W]	Qk[W]	Qs[W]	Qk[W]	Qs[W]
1200	30	45	114	88	337	268	686	563	802	685	935	821
	28	50	101	76	297	233	603	491	708	597	823	714
	26	50	69	64	200	198	<b>441</b>	<b>441</b>	539	539	635	635
	24	50	58	58	175	175	369	369	448	448	528	528
1600	30	45	171	131	506	402	1029	845	1204	1028	1402	1231
	28	50	151	114	445	350	905	736	1062	896	1234	1072
	26	50	103	96	299	296	<b>662</b>	<b>662</b>	808	808	952	952
	24	50	88	88	263	263	554	554	672	672	791	791
2000	30	45	228	175	675	536	1372	1127	1605	1370	1869	1641
	28	50	201	152	594	467	1207	982	1416	1195	1645	1429
	26	50	137	128	399	395	<b>883</b>	<b>883</b>	1078	1078	1269	1269
	24	50	117	117	351	351	738	738	897	897	1055	1055
2400	30	45	285	219	843	670	1715	1408	2006	1713	2336	2052
	28	50	252	191	742	583	1508	1227	1770	1494	2056	1786
	26	50	172	160	499	494	<b>1104</b>	<b>1104</b>	1347	1347	1587	1587
	24	50	146	146	439	439	923	923	1121	1121	1319	1319
2800	30	45	342	263	1012	804	2058	1690	2407	2055	2804	2462
	28	50	302	229	891	700	1810	1473	2124	1792	2468	2143
	26	50	206	192	599	593	<b>1324</b>	<b>1324</b>	1616	1616	1904	1904
	24	50	175	175	526	526	1108	1108	1345	1345	1583	1583

### Q [W] 16/18 °C

Speed level			Minimal		Standard level						Maximal	
SPEED			1		2		3		4		5	
LENGTH [mm]	Ti [°C]	r.v. [%]	COOLING OUTPUT [W]									
			Qk[W]	Qs[W]	Qk[W]	Qs[W]	Qk[W]	Qs[W]	Qk[W]	Qs[W]	Qk[W]	Qs[W]
1200	30	45	72	72	222	222	473	473	584	584	693	693
	28	50	61	61	189	189	402	402	495	495	587	587
	26	50	51	51	156	156	<b>330</b>	<b>330</b>	407	407	481	481
	24	50	40	40	122	122	259	259	317	317	374	374
1600	30	45	107	107	333	333	709	709	876	876	1039	1039
	28	50	92	92	283	283	602	602	743	743	881	881
	26	50	76	76	234	234	<b>495</b>	<b>495</b>	610	610	722	722
	24	50	59	59	184	184	388	388	475	475	561	561
2000	30	45	143	143	443	443	946	946	1168	1168	1385	1385
	28	50	122	122	378	378	803	803	991	991	1175	1175
	26	50	102	102	312	312	<b>660</b>	<b>660</b>	814	814	962	962
	24	50	79	79	245	245	518	518	633	633	748	748
2400	30	45	179	179	554	554	1182	1182	1460	1460	1731	1731
	28	50	153	153	472	472	1004	1004	1239	1239	1468	1468
	26	50	127	127	390	390	<b>825</b>	<b>825</b>	1017	1017	1203	1203
	24	50	99	99	306	306	647	647	791	791	935	935
2800	30	45	215	215	665	665	1419	1419	1752	1752	2078	2078
	28	50	184	184	567	567	1205	1205	1486	1486	1762	1762
	26	50	152	152	468	468	<b>991</b>	<b>991</b>	1221	1221	1443	1443
	24	50	119	119	367	367	776	776	950	950	1121	1121

Qk [W] - total cooling output, Qs[W] - sensible cooling output RH[%] - relative humidity

## CONDENSATE

If the cooling system is dimensioned so that condensate may occur (Qs < Qk), it is necessary to drain it from the convector. Condensate drips from lamellas of the exchanger to a drain chute, from which it flows out through a pipe on the convector right side. If condensate needs to be delivered to a collecting container or to a position above the convector, please use the condensate pump. Before use, check correct operation of the pump and its tightness by filling it with a small water amount through the exchanger. A float chamber must be cleaned from deposit dirt from time to time. Please follow instructions in the attached user manual.

## EXAMPLE OF CONNECTION OF A FLOOR CONVECTOR WITH A CONDENSATE PUMP

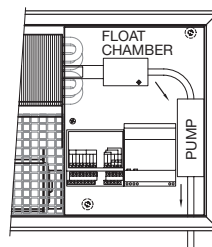



## PARAMETERS

<b>Convector</b>	Width	320 mm
	Height	134 mm
	Length	1200-2800 mm in step 400 mm
	Height adjusting	0-35 mm
	Stainless trough width	280 mm
	Grill type	cross / linear
	Grill material	anodized aluminium, wood, stainless steel
<b>Exchanger</b>	Width	100 mm
	Height	65 mm
	Finned length	L-465 mm
	Heat medium connection	4 x G1/2" female thread (4 pipe system)
	Max. working temperature	110 °C
<b>Fan</b>	Max. working overpressure	1 MPa
	Rotor diameter	∅ 60 mm
	Operating voltage	input to convector 230V AC, fans 24V DC
	Ingress protection	IP20
<b>Operating conditions</b>	Regulation	control voltage 0-10V (installed regulation)
	Ambient temperature	+2 to +40 °C
	Relative humidity	20-70 %

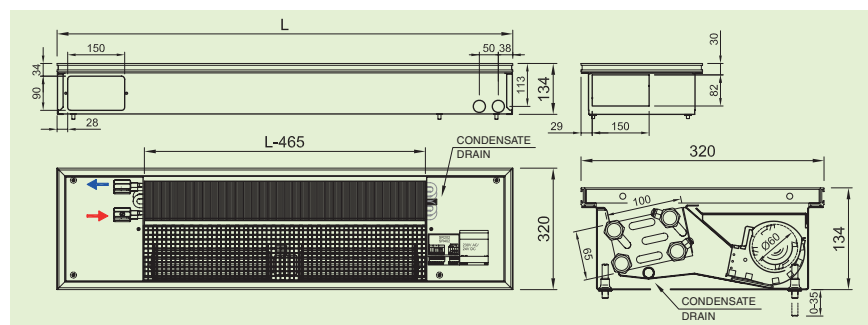

	SPEED	LENGTH [mm]				
		1200	1600	2000	2400	2800
<b>ACOUSTIC PRESSURE</b> LpAmax [dB(A)]	1	<20	<20	<20	<20	<20
	2	20	22	25	25	25
	3	30	32	34	35	36
	4	40	42	44	45	46
	5	48	49	51	52	53
<b>AIR VOLUME</b> [m³/h]	1	47	66	100	114	147
	2	89	123	179	195	266
	3	134	191	266	336	394
	4	179	255	356	449	526
	5	212	302	422	532	624

<b>Code example</b>	<b>FCC4A-13240-NR217</b>	Floor convector FCC4A-13, H=134 mm, W=320 mm, L=2400 mm, stainless steel trough, Al bronze frame, Al bronze cross roll-up grill, installed regulation, convector with fans 24V DC
---------------------	--------------------------	---

Regulation is always a part of the convector, black covers of water and electricity. Ordering, see the page 44

## SPECIFICATION

- Fully glazed rooms with big heat gains
- Flats, villas, residences, hotels
- High heat output
- Optimum after-cooling output
- Convection with tangential fans
- Silent operation
- Dry environment
- Safety voltage 24 V
- Low consumption of electric energy
- Easy operation

## HEATING OUTPUT

### Q [W] 90/70/20 °C

Speed level	Minimal	Standard level			Maximal
SPEED	1	2	3	4	5
LENGTH [mm]	HEATING OUTPUT Q <sub>h</sub> [W]				
1200	438	995	1621	1977	2141
1600	657	1493	2431	2965	3211
2000	876	1990	3242	3954	4281
2400	1095	2488	4052	4942	5352
2800	1314	2985	4862	5931	6422

### Qn [W] 75/65/20 °C

Speed level	Minimal	Standard level			Maximal
SPEED	1	2	3	4	5
LENGTH [mm]	HEATING OUTPUT Q <sub>h</sub> [W]				
1200	364	827	1347	1643	1779
1600	546	1241	2021	2465	2669
2000	728	1654	2694	3286	3558
2400	910	2068	3368	4108	4448
2800	1092	2481	4041	4929	5337

### Q [W] 70/55/20 °C

Speed level	Minimal	Standard level			Maximal
SPEED	1	2	3	4	5
LENGTH [mm]	HEATING OUTPUT Q <sub>h</sub> [W]				
1200	309	701	1142	1393	1508
1600	463	1052	1713	2090	2263
2000	617	1402	2284	2786	3017
2400	772	1753	2855	3483	3771
2800	926	2104	3426	4179	4525

### Q [W] 55/45/20 °C

Speed level	Minimal	Standard level			Maximal
SPEED	1	2	3	4	5
LENGTH [mm]	HEATING OUTPUT Q <sub>h</sub> [W]				
1200	217	492	802	978	1059
1600	325	739	1203	1467	1589
2000	433	985	1604	1957	2119
2400	542	1231	2005	2446	2648
2800	650	1477	2406	2935	3178



Q [W] 6/12 °C

Speed level			Minimal		Standard level						Maximal	
SPEED			1		2		3		4		5	
LENGTH [mm]	Ti [°C]	r.v. [%]	COOLING OUTPUT [W]									
			Qk[W]	Qs[W]	Qk[W]	Qs[W]	Qk[W]	Qs[W]	Qk[W]	Qs[W]	Qk[W]	Qs[W]
1200	30	45	166	108	493	329	974	671	1087	781	1137	853
	28	50	154	98	456	297	900	604	1005	701	1050	764
	<b>26</b>	<b>50</b>	<b>126</b>	<b>87</b>	<b>369</b>	<b>264</b>	<b>726</b>	<b>540</b>	<b>810</b>	<b>630</b>	<b>847</b>	<b>688</b>
	24	50	98	75	285	230	559	474	623	558	650	611
1600	30	45	250	162	739	493	1461	1007	1630	1172	1706	1280
	28	50	231	146	684	445	1350	906	1507	1051	1576	1145
	<b>26</b>	<b>50</b>	<b>189</b>	<b>130</b>	<b>554</b>	<b>397</b>	<b>1090</b>	<b>810</b>	<b>1216</b>	<b>945</b>	<b>1270</b>	<b>1032</b>
	24	50	148	113	427	346	838	711	934	836	975	916
2000	30	45	333	216	986	657	1948	1343	2174	1562	2275	1706
	28	50	308	195	912	593	1800	1207	2010	1402	2101	1527
	<b>26</b>	<b>50</b>	<b>253</b>	<b>174</b>	<b>739</b>	<b>529</b>	<b>1453</b>	<b>1080</b>	<b>1621</b>	<b>1260</b>	<b>1693</b>	<b>1376</b>
	24	50	197	151	570	461	1117	948	1245	1115	1301	1221
2400	30	45	416	271	1232	821	2435	1679	2717	1953	2843	2133
	28	50	385	244	1140	741	2251	1509	2512	1752	2626	1909
	<b>26</b>	<b>50</b>	<b>316</b>	<b>217</b>	<b>924</b>	<b>661</b>	<b>1816</b>	<b>1350</b>	<b>2026</b>	<b>1576</b>	<b>2116</b>	<b>1720</b>
	24	50	246	189	712	576	1396	1185	1557	1394	1626	1527
2800	30	45	499	325	1479	986	2921	2014	3261	2343	3412	2560
	28	50	463	293	1368	890	2701	1811	3014	2103	3151	2291
	<b>26</b>	<b>50</b>	<b>379</b>	<b>261</b>	<b>1108</b>	<b>793</b>	<b>2179</b>	<b>1620</b>	<b>2431</b>	<b>1891</b>	<b>2540</b>	<b>2064</b>
	24	50	295	226	855	691	1676	1422	1868	1673	1951	1832

Q [W] 8/14 °C

Speed level			Minimal		Standard level						Maximal	
SPEED			1		2		3		4		5	
LENGTH [mm]	Ti [°C]	r.v. [%]	COOLING OUTPUT [W]									
			Qk[W]	Qs[W]	Qk[W]	Qs[W]	Qk[W]	Qs[W]	Qk[W]	Qs[W]	Qk[W]	Qs[W]
1200	30	45	140	96	411	294	807	602	897	707	937	778
	28	50	128	86	373	261	732	534	814	625	850	687
	<b>26</b>	<b>50</b>	<b>98</b>	<b>75</b>	<b>284</b>	<b>227</b>	<b>555</b>	<b>469</b>	<b>617</b>	<b>554</b>	<b>645</b>	<b>611</b>
	24	50	68	63	195	192	432	432	509	509	549	549
1600	30	45	210	144	617	440	1210	903	1346	1060	1406	1167
	28	50	192	129	560	391	1099	801	1221	938	1276	1031
	<b>26</b>	<b>50</b>	<b>148</b>	<b>112</b>	<b>426</b>	<b>341</b>	<b>832</b>	<b>704</b>	<b>926</b>	<b>831</b>	<b>967</b>	<b>916</b>
	24	50	102	95	293	289	648	648	764	764	824	824
2000	30	45	280	192	822	587	1614	1204	1794	1413	1874	1555
	28	50	256	172	747	521	1465	1068	1628	1251	1701	1374
	<b>26</b>	<b>50</b>	<b>197</b>	<b>149</b>	<b>568</b>	<b>455</b>	<b>1109</b>	<b>938</b>	<b>1234</b>	<b>1108</b>	<b>1289</b>	<b>1221</b>
	24	50	136	126	391	385	864	864	1019	1019	1099	1099
2400	30	45	351	240	1028	734	2017	1504	2243	1767	2343	1944
	28	50	320	215	933	651	1831	1335	2035	1564	2126	1718
	<b>26</b>	<b>50</b>	<b>246</b>	<b>187</b>	<b>710</b>	<b>569</b>	<b>1387</b>	<b>1173</b>	<b>1543</b>	<b>1384</b>	<b>1612</b>	<b>1527</b>
	24	50	170	158	489	481	1080	1080	1274	1274	1373	1373
2800	30	45	421	288	1234	881	2421	1805	2692	2120	2812	2333
	28	50	384	258	1120	782	2197	1602	2443	1876	2551	2061
	<b>26</b>	<b>50</b>	<b>295</b>	<b>224</b>	<b>852</b>	<b>682</b>	<b>1664</b>	<b>1408</b>	<b>1851</b>	<b>1661</b>	<b>1934</b>	<b>1832</b>
	24	50	204	189	586	577	1296	1296	1528	1528	1648	1648

Q [W] 12/16 °C

Speed level			Minimal		Standard level						Maximal	
SPEED			1		2		3		4		5	
LENGTH [mm]	Ti [°C]	r.v. [%]	COOLING OUTPUT [W]									
			Qk[W]	Qs[W]	Qk[W]	Qs[W]	Qk[W]	Qs[W]	Qk[W]	Qs[W]	Qk[W]	Qs[W]
1200	30	45	103	81	299	250	588	519	654	617	704	704
	28	50	90	71	262	218	513	451	571	536	599	597
	<b>26</b>	<b>50</b>	<b>62</b>	<b>62</b>	<b>196</b>	<b>196</b>	<b>405</b>	<b>405</b>	<b>481</b>	<b>481</b>	<b>523</b>	<b>523</b>
	24	50	53	53	163	163	337	337	399	399	431	431
1600	30	45	154	122	449	375	882	779	981	926	1056	1056
	28	50	135	106	394	327	770	676	856	804	899	896
	<b>26</b>	<b>50</b>	<b>92</b>	<b>92</b>	<b>295</b>	<b>295</b>	<b>608</b>	<b>608</b>	<b>722</b>	<b>722</b>	<b>784</b>	<b>784</b>
	24	50	80	80	245	245	505	505	599	599	647	647
2000	30	45	205	162	599	500	1176	1039	1308	1234	1408	1408
	28	50	180	141	525	436	1027	901	1142	1072	1199	1195
	<b>26</b>	<b>50</b>	<b>123</b>	<b>123</b>	<b>393</b>	<b>393</b>	<b>811</b>	<b>811</b>	<b>962</b>	<b>962</b>	<b>1046</b>	<b>1046</b>
	24	50	107	107	327	327	673	673	798	798	863	863
2400	30	45	256	203	749	625	1470	1298	1635	1543	1760	1760
	28	50	226	176	656	544	1284	1126	1427	1340	1498	1494
	<b>26</b>	<b>50</b>	<b>154</b>	<b>154</b>	<b>491</b>	<b>491</b>	<b>1014</b>	<b>1014</b>	<b>1203</b>	<b>1203</b>	<b>1307</b>	<b>1307</b>
	24	50	133	133	408	408	842	842	998	998	1078	1078
2800	30	45	308	244	898	750	1764	1558	1961	1851	2112	2112
	28	50	271	212	787	653	1540	1352	1712	1608	1798	1792
	<b>26</b>	<b>50</b>	<b>185</b>	<b>185</b>	<b>589</b>	<b>589</b>	<b>1216</b>	<b>1216</b>	<b>1443</b>	<b>1443</b>	<b>1569</b>	<b>1569</b>
	24	50	160	160	490	490	1010	1010	1197	1197	1294	1294

Qk [W] - total cooling output, Qs[W] - sensible cooling output RH[%] - relative humidity

## CONDENSATE

If the cooling system is dimensioned so that condensate may occur (Qs < Qk), it is necessary to drain it from the convector. Condensate drips from lamellas of the exchanger to a drain chute, from which it flows out through a pipe on the convector right side. If condensate needs to be delivered to a collecting container or to a position above the convector, please use the condensate pump. Before use, check correct operation of the pump and its tightness by filling it with a small water amount through the exchanger. A float chamber must be cleaned from deposit dirt from time to time. Please follow instructions in the attached user manual.

## EXAMPLE OF CONNECTION OF A FLOOR CONVECTOR WITH A CONDENSATE PUMP

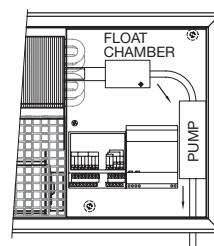





## PARAMETERS

<b>Convector</b>	Width	270 mm
	Height	125 mm
	Length	800–4800 mm in step 400 mm
	Height adjusting	adjusting leg
	Stainless trough width	250 mm
	Grill type	cross / linear
	Grill material	anodized aluminium, stainless steel
<b>Exchanger</b>	Width	2 × Ø 65 mm
	Height	
	Finned length	L-440mm
	Heat medium connection	2 × G1/2" female thread
	Max. working temperature	110 °C
<b>Fan</b>	Max. working overpressure	1 MPa
	Rotor diameter	Ø 90 mm
	Operating voltage	<b>Safe voltage 12V DC</b>
	Ingress protection	<b>IP55</b>
<b>Operating conditions</b>	Regulation	by output voltage modification (regulator RB25, ...)
	Ambient temperature	+2 to +40 °C
	Relative humidity	20–70%

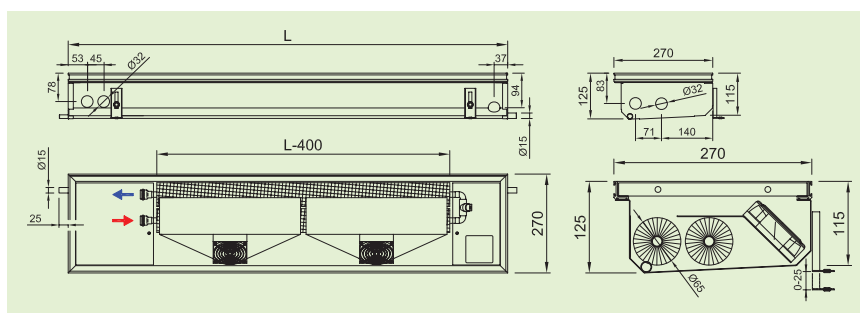

	SPEED	LENGHT [mm]											
		800	1200	1600	2000	2400	2800	3200	3600	4000	4400	4800	
<b>ACOUSTIC PRESSURE</b> LpAmax [dB(A)]	1	38	40	40	40	41	41	41	42	42	42	42	42
	2	41	43	44	45	46	46	46	46	46	46	46	46
	3	45	48	48	48	49	49	49	50	50	50	50	50
<b>AIR VOLUME</b> [m³/h]	1	28	63	93	126	154	190	224	254	293	307	335	
	2	42	95	137	190	219	290	319	382	412	440	488	
	3	62	138	200	274	341	413	499	550	658	691	753	

**Code example** **FLB20-12200-NR110** Floor convector FLB20-12, H=125mm, W=270mm, L=2000mm, stainless steel trough, Al natur frame, Al natur cross roll-up grill, no regulation (not possible to place regulator inside the convector), convector 12V DC

Ordering, see the page 44

Heat output **90/70/20 °C** – multiply values **75/65/20 °C** by a coefficient **1,21** | Heat output **55/45/20 °C** – multiply values **75/65/20 °C** by a coefficient **0,59**

## SPECIFICATIONS

- full-area glassed rooms with high heat gains
- pools, wellness, winter gardens
- possibility to be flooded for a short time
- forced convection with axial fans
- heating and cooling
- low consumption of electric energy
- safe voltage of 12 V
- easy control
- Cu-Cu heat exchanger
- easy cleaning – hygiene
- designed for wet conditions

## HEATING OUTPUT

Q [W] 75/65/20 °C

LENGHT [mm]	SPEED rpm	HEATING OUTPUT [W]			
		0	1	2	3
800	20	116	440	506	557
	24	103	403	464	511
	28	90	367	422	465
1200	20	231	879	1012	1114
	24	205	806	928	1022
	28	180	734	845	930
1600	20	347	1319	1518	1671
	24	308	1210	1392	1533
	28	270	1101	1267	1395
2000	20	463	1758	2024	2228
	24	410	1613	1857	2044
	28	360	1468	1690	1861
2400	20	578	2198	2530	2785
	24	513	2016	2321	2555
	28	450	1835	2112	2326
2800	20	694	2637	3035	3342
	24	615	2419	2785	3066
	28	540	2202	2535	2791
3200	20	810	3077	3541	3899
	24	718	2823	3249	3577
	28	630	2569	2957	3256
3600	20	925	3516	4047	4456
	24	820	3226	3713	4088
	28	720	2937	3380	3721
4000	20	1041	3956	4553	5013
	24	923	3629	4177	4599
	28	809	3304	3802	4186
4400	20	1157	4395	5059	5570
	24	1026	4032	4641	5110
	28	899	3671	4225	4651
4800	20	1272	4835	5565	6126
	24	1128	4436	5106	5621
	28	989	4038	4647	5116

Q [W] 70/55/20 °C

LENGHT [mm]	SPEED rpm	HEATING OUTPUT [W]			
		0	1	2	3
800	20	91	372	428	471
	24	78	332	382	421
	28	66	296	340	375
1200	20	183	743	855	942
	24	156	664	765	842
	28	133	591	681	749
1600	20	274	1115	1283	1413
	24	235	997	1147	1263
	28	199	887	1021	1124
2000	20	366	1486	1711	1883
	24	313	1329	1530	1684
	28	266	1183	1361	1498
2400	20	457	1858	2138	2354
	24	391	1661	1912	2105
	28	332	1478	1701	1873
2800	20	549	2229	2566	2825
	24	469	1993	2294	2526
	28	399	1774	2042	2248
3200	20	640	2601	2994	3296
	24	548	2326	2677	2947
	28	465	2069	2382	2622
3600	20	732	2973	3422	3767
	24	626	2658	3059	3368
	28	532	2365	2722	2997
4000	20	823	3344	3849	4238
	24	704	2990	3442	3789
	28	598	2661	3062	3372
4400	20	915	3716	4277	4709
	24	782	3322	3824	4210
	28	665	2956	3403	3746
4800	20	1006	4087	4705	5179
	24	861	3654	4206	4631
	28	731	3252	3743	4121



**Q [W] 6/12 °C, relative humidity 55 %**

SPEED		1		2		3	
rpm		COOLING OUTPUT [W]					
LENGTH [mm]	Ti [°C]	Qk[W]	Qs[W]	Qk[W]	Qs[W]	Qk[W]	Qs[W]
1200	24	256	160	274	174	299	194
	26	281	176	301	191	328	213
	28	305	191	327	207	356	232
	30	328	206	352	223	384	249
1600	24	384	241	412	261	449	292
	26	421	264	452	286	492	320
	28	457	287	490	311	535	347
	30	493	309	528	335	576	374
2000	24	512	321	549	348	598	389
	26	562	352	602	382	657	427
	28	610	382	654	414	713	463
	30	657	412	704	446	768	499
2400	24	640	401	686	435	748	486
	26	702	440	753	477	821	533
	28	762	478	817	518	891	579
	30	821	514	880	558	960	624
2800	24	768	481	823	522	898	583
	26	843	528	903	572	985	640
	28	915	573	980	622	1 069	695
	30	985	617	1 056	669	1 151	748
3200	24	896	562	960	609	1 047	681
	26	983	616	1 054	668	1 149	747
	28	1 067	669	1 144	725	1 247	811
	30	1 150	720	1 232	781	1 343	873

**Q [W] 8/14 °C, relative humidity 55 %**

SPEED		1		2		3	
rpm		COOLING OUTPUT [W]					
LENGTH [mm]	Ti [°C]	Qk[W]	Qs[W]	Qk[W]	Qs[W]	Qk[W]	Qs[W]
1200	24	230	144	247	156	269	175
	26	256	160	274	174	299	194
	28	281	176	301	191	328	213
	30	305	191	327	207	356	232
1600	24	345	216	370	235	404	262
	26	384	241	412	261	449	292
	28	421	264	452	286	492	320
	30	457	287	490	311	535	347
2000	24	461	289	494	313	538	350
	26	512	321	549	348	598	389
	28	562	352	602	382	657	427
	30	610	382	654	414	713	463
2400	24	576	361	617	391	673	437
	26	640	401	686	435	748	486
	28	702	440	753	477	821	533
	30	762	478	817	518	891	579
2800	24	691	433	740	469	807	525
	26	768	481	823	522	898	583
	28	843	528	903	572	985	640
	30	915	573	980	622	1 069	695
3200	24	806	505	864	548	942	612
	26	896	562	960	609	1 047	681
	28	983	616	1 054	668	1 149	747
	30	1 067	669	1 144	725	1 247	811

**Q [W] 10/15 °C, relative humidity 55 %**

SPEED		1		2		3	
rpm		COOLING OUTPUT [W]					
LENGTH [mm]	Ti [°C]	Qk[W]	Qs[W]	Qk[W]	Qs[W]	Qk[W]	Qs[W]
1200	24	210	132	225	143	246	160
	26	237	148	254	161	277	180
	28	262	164	281	178	307	199
	30	287	180	308	195	335	218
1600	24	316	198	338	214	369	240
	26	355	223	381	241	415	270
	28	394	247	422	267	460	299
	30	430	270	461	292	503	327
2000	24	421	264	451	286	492	319
	26	474	297	508	322	554	360
	28	525	329	562	356	613	398
	30	574	360	615	390	671	436
2400	24	526	329	563	357	615	399
	26	592	371	634	402	692	450
	28	656	411	703	445	766	498
	30	717	450	769	487	838	545
2800	24	631	395	676	429	737	479
	26	711	445	761	483	830	540
	28	787	493	843	535	920	598
	30	861	539	923	585	1 006	654
3200	24	736	461	789	500	860	559
	26	829	519	888	563	969	629
	28	918	575	984	624	1 073	697
	30	1 004	629	1 076	682	1 174	763

**Q [W] 12/16 °C, relative humidity 55 %**

SPEED		1		2		3	
rpm		COOLING OUTPUT [W]					
LENGTH [mm]	Ti [°C]	Qk[W]	Qs[W]	Qk[W]	Qs[W]	Qk[W]	Qs[W]
1200	24	190	119	203	129	222	144
	26	217	136	233	147	254	165
	28	243	152	261	165	284	185
	30	269	168	288	182	314	204
1600	24	285	178	305	193	332	216
	26	326	204	349	221	381	247
	28	365	229	391	248	426	277
	30	403	252	432	274	471	306
2000	24	379	238	407	258	443	288
	26	434	272	465	295	507	330
	28	487	305	521	331	569	370
	30	537	337	576	365	628	408
2400	24	474	297	508	322	554	360
	26	543	340	582	369	634	412
	28	608	381	652	413	711	462
	30	671	421	719	456	785	510
2800	24	569	357	610	387	665	432
	26	651	408	698	442	761	495
	28	730	457	782	496	853	554
	30	806	505	863	547	942	612
3200	24	664	416	711	451	776	504
	26	760	476	814	516	888	577
	28	852	534	913	578	995	647
	30	940	589	1 007	639	1 098	714

**Q [W] 14/18 °C, relative humidity 55 %**

SPEED		1		2		3	
rpm		COOLING OUTPUT [W]					
LENGTH [mm]	Ti [°C]	Qk[W]	Qs[W]	Qk[W]	Qs[W]	Qk[W]	Qs[W]
1200	24	91	91	99	99	111	111
	26	110	110	119	119	133	133
	28	204	128	218	138	238	155
	30	230	144	247	156	269	175
1600	24	137	137	148	148	166	166
	26	165	165	179	179	200	200
	28	305	191	327	207	357	232
	30	345	216	370	235	404	262
2000	24	183	183	198	198	221	221
	26	220	220	238	238	266	266
	28	407	255	436	277	476	309
	30	461	289	494	313	538	350

**Q [W] 14/18 °C, relative humidity 55 %**

SPEED		1		2		3	
rpm		COOLING OUTPUT [W]					
LENGTH [mm]	Ti [°C]	Qk[W]	Qs[W]	Qk[W]	Qs[W]	Qk[W]	Qs[W]
2400	274	274	297	297	332	332	239
	330	330	358	358	400	400	300
	611	383	654	415	714	464	360
	691	433	740	469	807	525	419
2800	319	319	346	346	387	387	286
	385	385	417	417	466	466	360
	712	446	763	484	832	541	432
	806	505	864	548	942	612	503
3200	365	365	396	396	442	442	334
	440	440	477	477	533	533	420
	814	510	872	553	951	618	504
	921	577	987	626	1 077	700	587

Qk [W] - total cooling output, Qs[W] - sensible cooling output (air relative humidity 55 %)



## HEATING OUTPUT RECALCULATION FOR ANOTHER TEMPERATURE GRADIENT

Convector heating output reckoning follows by recalculation of the standardized output  $Q_n$  75/65/20 °C

$$Q = Q_n * \Psi * \left( \frac{\Delta T}{50} \right)^m \text{ [W]; where } \Delta T = \left( \frac{T_1 + T_2}{2} \right) - T_i \text{ [}^\circ\text{C]}$$

$m = 1,45$  for FLK10-09 to FLK 40-14  
 $m = 1,42$  for FLK20-18 and FLK30-18  
 $m = 1,49$  for FLK20-30 and FLK30-30

$Q_n$  [W] heating output for temperature gradient  $T_1/T_2/T_i = 75/65/20$  °C  
 $\Psi$  [-] mass rate of flow coefficient (for current flow rate  $\psi=1$ )  
 $T_1$  [°C] input water temperature  
 $T_2$  [°C] output water temperature  
 $T_i$  [°C] temperature in the room  
 $m$  [-] temperature exponent

## QUICK CONVERSION TO $T_i=22$ °C A $T_i=15$ °C FOR ORIENTATION

- If you want to learn convector output for the room temperature of 22 °C or for a corridor temperature of 15 °C
- multiply heating output of the chosen convector by the "k" coefficient

For  $T_i=22$ °C,  $k=0.95$   
 E.g.:  $Q$  [55/45/22 °C] = 0.95 \*  $Q$  [55/45/20 °C]

for  $T_i=15$ °C,  $k=1.12$   
 E.g.:  $Q$  [75/65/15 °C] = 1.12 \*  $Q_n$  [75/65/20 °C]

## HEATING WATER FLOW RATE THROUGH EXCHANGER

$$M = 0.86Q / (T_1 - T_2) \text{ [kg/h]}$$

$M$  [kg/h] mass rate of flow, heating water flowing through exchanger  
 $Q$  [W] convector heating output  
 $T_1 - T_2$  [°C] difference between input and output temperature  
 0.86 [-] invariable for recalculation of units

## EXCHANGER HYDRAULIC LOSSES

TYPE	Length [mm]	Volume [l]	M – mass rate of flow in piping (kg/h) / R – hydraulic loss in exchanger (kPa)												
			M=20	40	60	80	100	120	150	200	250	300	350	400	450
FLK10-09 FLK10-11 FLK10-14 FLK20-09 FLK20-11 FLK20-14 FLK20-18 FLK20-30	800	0,11	0,01	0,03	0,06	0,11	0,17	0,25	0,39	0,69	1,07	1,55	2,11	2,75	3,48
	1200	0,21	0,01	0,03	0,08	0,14	0,21	0,30	0,48	0,85	1,32	1,91	2,59	3,39	4,29
	1600	0,32	0,01	0,04	0,09	0,15	0,24	0,34	0,53	0,94	1,48	2,13	2,89	3,78	4,78
	2000	0,43	0,01	0,04	0,09	0,16	0,26	0,37	0,58	1,02	1,60	2,30	3,13	4,09	5,18
	2400	0,53	0,01	0,05	0,10	0,19	0,29	0,42	0,65	1,16	1,81	2,61	3,55	4,64	5,87
	2800	0,64	0,01	0,05	0,11	0,19	0,30	0,43	0,68	1,20	1,88	2,71	3,69	4,82	6,09
	3200	0,74	0,01	0,06	0,13	0,23	0,35	0,51	0,79	1,41	2,21	3,18	4,33	5,65	7,15
	3600	0,85	0,01	0,06	0,13	0,23	0,36	0,53	0,82	1,46	2,28	3,28	4,47	5,84	7,39
	4000	0,96	0,02	0,09	0,20	0,36	0,56	0,81	1,27	2,26	3,52	5,08	6,91	9,02	11,42
	4800	1,17	0,02	0,09	0,21	0,37	0,58	0,84	1,31	2,33	3,64	5,24	7,14	9,32	11,80
FLK30-09 FLK30-11 FLK30-14 FLK30-18 FLK30-30	800	0,17	0,01	0,04	0,09	0,16	0,25	0,36	0,56	1,00	1,55	2,24	3,05	3,98	5,04
	1200	0,32	0,01	0,04	0,10	0,18	0,27	0,39	0,62	1,10	1,71	2,47	3,36	4,39	5,55
	1600	0,48	0,01	0,05	0,12	0,22	0,34	0,49	0,76	1,36	2,12	3,05	4,15	5,43	6,87
	2000	0,65	0,02	0,07	0,16	0,28	0,44	0,63	0,98	1,74	2,72	3,92	5,33	6,96	8,81
	2400	0,80	0,02	0,09	0,21	0,37	0,58	0,83	1,30	2,32	3,62	5,21	7,09	9,26	11,72
	2800	0,96	0,03	0,10	0,23	0,40	0,63	0,91	1,42	2,52	3,93	5,67	7,71	10,07	12,75
	3200	1,11	0,03	0,11	0,25	0,44	0,69	0,99	1,55	2,75	4,30	6,19	8,43	11,01	13,93
	3600	1,28	0,03	0,13	0,28	0,50	0,78	1,13	1,76	3,13	4,89	7,05	9,59	12,53	15,86
	4000	1,44	0,04	0,16	0,36	0,63	0,99	1,43	2,23	3,97	6,20	8,93	12,15	15,87	20,09
	4800	1,59	0,05	0,18	0,41	0,74	1,15	1,66	2,59	4,60	7,20	10,36	14,10	18,42	23,31
FLK40-09 FLK40-11 FLK40-14	800	0,22	0,01	0,03	0,07	0,13	0,20	0,29	0,45	0,80	1,24	1,79	2,44	3,18	4,03
	1200	0,42	0,01	0,04	0,08	0,14	0,22	0,32	0,49	0,88	1,37	1,97	2,69	3,51	4,44
	1600	0,64	0,01	0,04	0,10	0,17	0,27	0,39	0,61	1,09	1,70	2,44	3,32	4,34	5,49
	2000	0,86	0,01	0,06	0,13	0,22	0,35	0,50	0,78	1,39	2,18	3,13	4,26	5,57	7,05
	2400	1,06	0,02	0,07	0,17	0,30	0,46	0,67	1,04	1,85	2,89	4,17	5,67	7,41	9,38
	2800	1,28	0,02	0,08	0,18	0,32	0,50	0,73	1,13	2,01	3,15	4,53	6,17	8,06	10,20
	3200	1,48	0,02	0,09	0,20	0,35	0,55	0,79	1,24	2,20	3,44	4,95	6,74	8,81	11,14
	3600	1,70	0,03	0,10	0,23	0,40	0,63	0,90	1,41	2,51	3,92	5,64	7,67	10,02	12,69
	4000	1,92	0,03	0,13	0,29	0,51	0,79	1,14	1,79	3,17	4,96	7,14	9,72	12,70	16,07
	4800	2,12	0,04	0,15	0,33	0,59	0,92	1,33	2,07	3,68	5,76	8,29	11,28	14,74	18,65
4800	2,34	0,04	0,17	0,38	0,67	1,04	1,50	2,35	4,17	6,52	9,39	12,78	16,69	21,12	

## PARAMETERS OF LOCKSHIELD VALVES

T-turns	0,5	0,75	1	1,5	2	2,5	3	3,5	4	5	6	MAX
Kv (m³/h) – direct version	0,3	0,4	0,55	0,75	0,91	1,05	1,25	1,33	1,4	1,6	1,7	1,8
Kv (m³/h) – corner version	0,2	0,25	0,29	0,4	0,5	0,69	0,8	1	1,2	1,55	1,9	2,2

parameters of free packed in lockshield valves



## FLK10-09 | NATURAL CONVECTION



### SPECIFICATIONS

- Width 170 mm
- Offices, corridors, halls, flats, winter garden
- High heating output of natural convection
- Suitable for combining with other heating systems
- Cu-Cu wire heat exchanger
- Mechanical resistance of the heat exchanger
- Easy cleaning - hygiene
- Using in dry ambience

## FLK20-09 | NATURAL CONVECTION



### SPECIFICATIONS

- Width 320 mm
- Offices, corridors, halls, flats, winter garden
- High heating output of natural convection
- Suitable for combining with other heating systems
- Cu-Cu wire heat exchanger
- Mechanical resistance of the heat exchanger
- Easy cleaning - hygiene
- Using in dry ambience

## FLK30-09 | NATURAL CONVECTION



### SPECIFICATIONS

- Width 360 mm
- Offices, corridors, halls, flats, winter garden
- High heating output of natural convection
- Suitable for combining with other heating systems
- Cu-Cu wire heat exchanger
- Mechanical resistance of the heat exchanger
- Easy cleaning - hygiene
- Using in dry ambience

## FLK40-09 | NATURAL CONVECTION



### SPECIFICATIONS

- Width 420 mm
- Offices, corridors, halls, flats, winter garden
- High heating output of natural convection
- Suitable for combining with other heating systems
- Cu-Cu wire heat exchanger
- Mechanical resistance of the heat exchanger
- Easy cleaning - hygiene
- Using in dry ambience

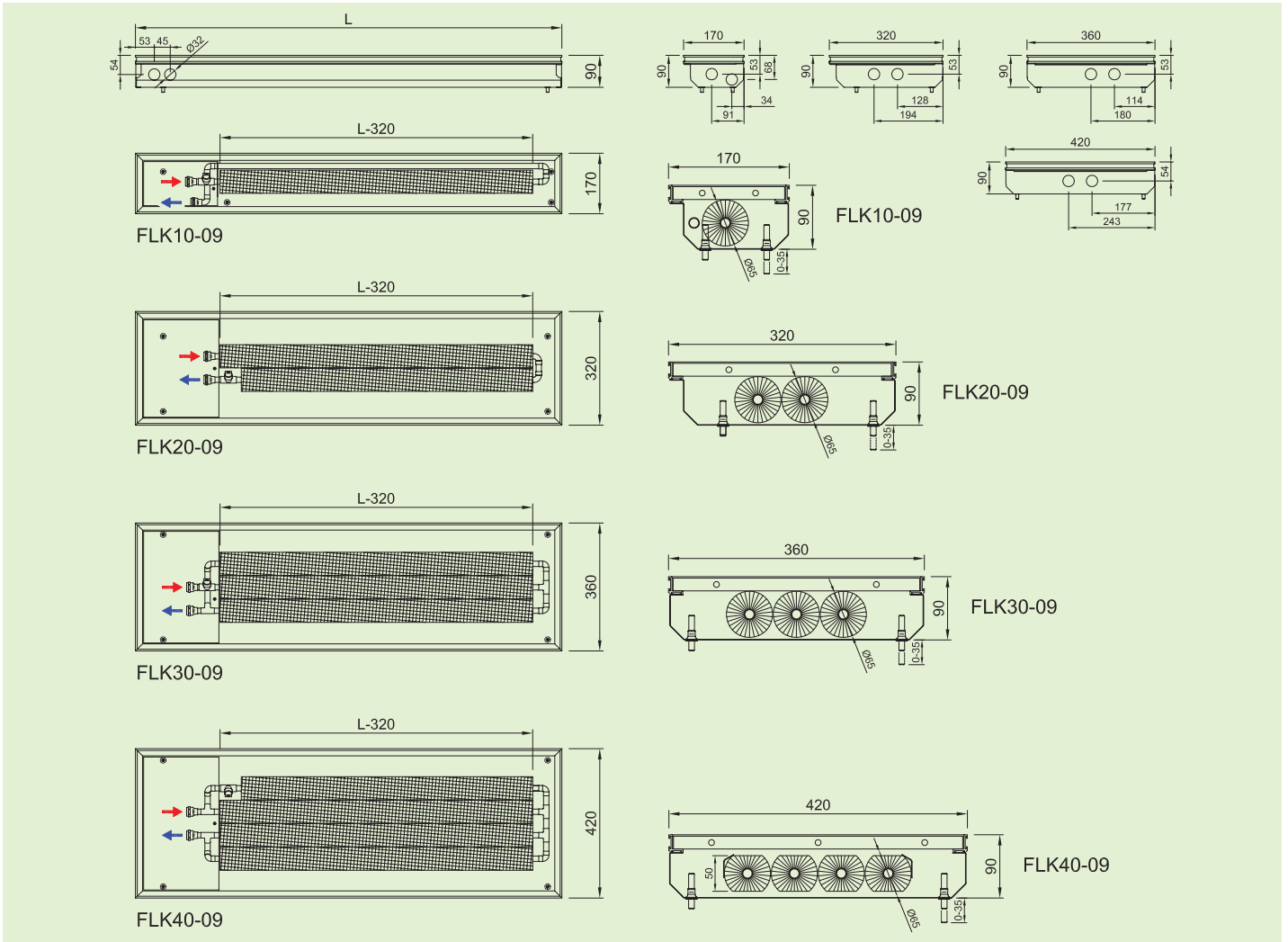

### HEATING OUTPUT

Q [W] 90/70/20°C

TYPE	FLK10-09	FLK20-09	FLK30-09	FLK40-09
LENGTH [mm]	HEATING OUTPUT [W]			
800	118	199	282	365
1200	214	366	511	656
1600	316	541	747	953
2000	419	721	986	1251
2400	523	902	1227	1552
2800	630	1088	1472	1856
3200	736	1276	1716	2156
3600	844	1466	1964	2462
4000	952	1657	2212	2767
4400	1063	1851	2462	3073
4800	1172	2046	2711	3376

Qn [W] 75/65/20°C

TYPE	FLK10-09	FLK20-09	FLK30-09	FLK40-09
LENGTH [mm]	HEATING OUTPUT [W]			
800	95	161	227	293
1200	173	296	413	530
1600	255	438	604	770
2000	338	583	797	1011
2400	422	730	992	1254
2800	508	880	1190	1500
3200	594	1032	1388	1744
3600	681	1186	1588	1990
4000	768	1341	1789	2237
4400	857	1498	1991	2484
4800	945	1655	2193	2731

Q [W] 70/55/20°C

TYPE	FLK10-09	FLK20-09	FLK30-09	FLK40-09
LENGTH [mm]	HEATING OUTPUT [W]			
800	75	127	179	231
1200	137	234	326	419
1600	201	346	477	608
2000	267	461	630	799
2400	333	577	784	991
2800	401	695	940	1185
3200	469	815	1097	1378
3600	538	937	1255	1572
4000	607	1059	1413	1767
4400	677	1184	1573	1962
4800	747	1308	1733	2158

Q [W] 55/45/20°C

TYPE	FLK10-09	FLK20-09	FLK30-09	FLK40-09
LENGTH [mm]	HEATING OUTPUT [W]			
800	45	76	118	160
1200	81	140	211	282
1600	120	208	307	406
2000	159	277	406	535
2400	199	347	506	665
2800	240	419	606	793
3200	280	492	708	924
3600	321	565	808	1051
4000	363	639	911	1183
4400	405	714	1015	1316
4800	446	789	1118	1447

### PARAMETERS

Convector	Width	170, 320, 360, 420 mm
	Height	90 mm
	Length	800-4800 mm in step 400 mm
	Height adjusting	0-35 mm
	Stainless trough width	150, 300, 360, 420 mm
	Grill type	cross / linear
	Grill material	anodized aluminium, wood, stainless steel
Exchanger	Width	1x, 2x, 3x, 4x Ø 6.5 mm
	Height	
	Finned length	L320 mm
	Heat medium connection	2 × G1/2" inner
	Max. working temperature	110 °C
Operating conditions	Max. working over-pressure	1 MPa
	Ambient temperature	+2 to +40 °C
	Relative humidity	20-70 %

## FLK10-11 | NATURAL CONVECTION



### SPECIFICATIONS

- Width 170 mm
- Offices, corridors, halls, flats, winter garden
- High heating output of natural convection
- Suitable for combining with other heating systems
- Cu-Cu wire heat exchanger
- Mechanical resistance of the heat exchanger
- Easy cleaning - hygiene
- Using in dry ambience

## FLK20-11 | NATURAL CONVECTION

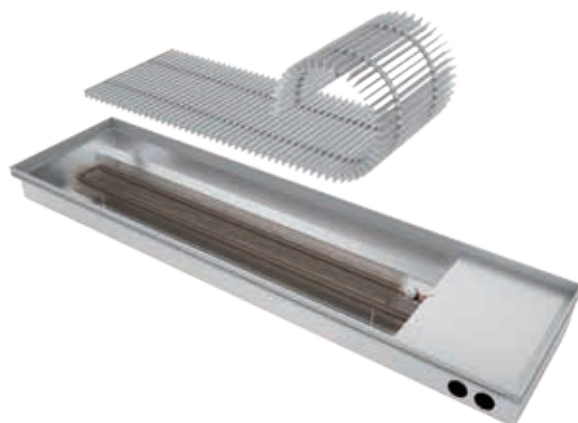

### SPECIFICATIONS

- Width 320 mm
- Offices, corridors, halls, flats, winter garden
- High heating output of natural convection
- Suitable for combining with other heating systems
- Cu-Cu wire heat exchanger
- Mechanical resistance of the heat exchanger
- Easy cleaning - hygiene
- Using in dry ambience

## FLK30-11 | NATURAL CONVECTION



### SPECIFICATIONS

- Width 360 mm
- Offices, corridors, halls, flats, winter garden
- High heating output of natural convection
- Suitable for combining with other heating systems
- Cu-Cu wire heat exchanger
- Mechanical resistance of the heat exchanger
- Easy cleaning - hygiene
- Using in dry ambience

## FLK40-11 | NATURAL CONVECTION



### SPECIFICATIONS

- Width 420 mm
- Offices, corridors, halls, flats, winter garden
- High heating output of natural convection
- Suitable for combining with other heating systems
- Cu-Cu wire heat exchanger
- Mechanical resistance of the heat exchanger
- Easy cleaning - hygiene
- Using in dry ambience



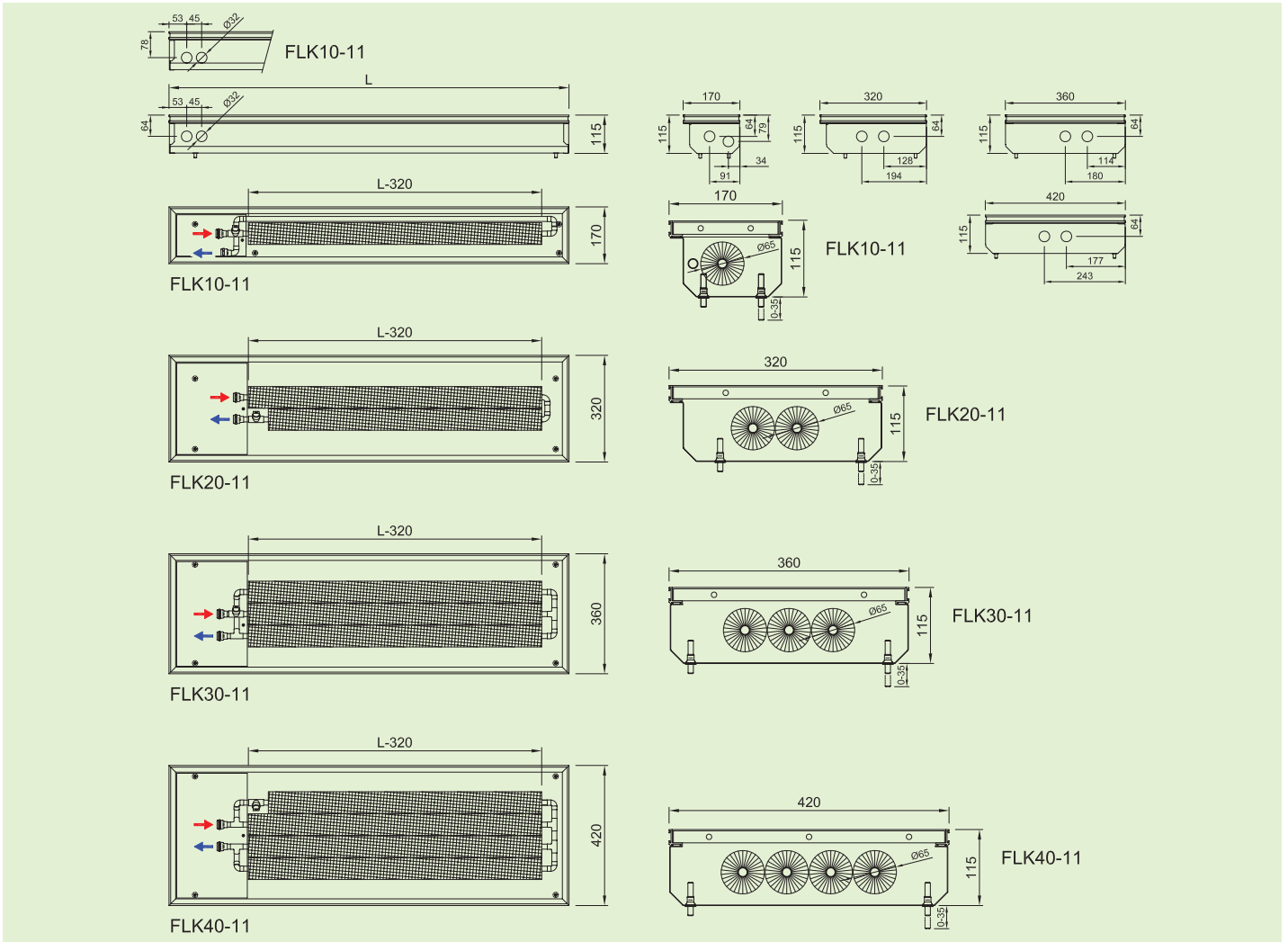

### HEATING OUTPUT

Q [W] 90/70/20°C

TYPE	FLK10-11	FLK20-11	FLK30-11	FLK40-11
LENGTH [mm]	HEATING OUTPUT [W]			
800	126	215	305	395
1200	230	398	546	694
1600	338	587	795	1003
2000	448	783	1052	1321
2400	560	980	1311	1642
2800	673	1182	1568	1954
3200	787	1386	1832	2278
3600	902	1592	2091	2590
4000	1019	1801	2358	2915
4400	1135	2011	2626	3241
4800	1253	2223	2895	3567

Qn [W] 75/65/20°C

TYPE	FLK10-11	FLK20-11	FLK30-11	FLK40-11
LENGTH [mm]	HEATING OUTPUT [W]			
800	102	174	246	318
1200	186	322	441	560
1600	273	475	642	809
2000	362	633	850	1067
2400	452	793	1060	1327
2800	543	956	1268	1580
3200	635	1121	1481	1841
3600	728	1288	1691	2094
4000	822	1457	1907	2357
4400	916	1627	2124	2621
4800	1011	1798	2341	2884

Q [W] 70/55/20°C

TYPE	FLK10-11	FLK20-11	FLK30-11	FLK40-11
LENGTH [mm]	HEATING OUTPUT [W]			
800	81	137	194	251
1200	147	254	348	442
1600	216	375	507	639
2000	286	500	672	843
2400	357	627	837	1048
2800	429	755	1002	1248
3200	502	886	1170	1454
3600	575	1018	1336	1654
4000	649	1151	1507	1862
4400	724	1285	1678	2071
4800	799	1421	1850	2279

Q [W] 55/45/20°C

TYPE	FLK10-11	FLK20-11	FLK30-11	FLK40-11
LENGTH [mm]	HEATING OUTPUT [W]			
800	48	84	118	152
1200	88	154	211	268
1600	129	227	307	387
2000	171	303	406	509
2400	213	379	506	633
2800	256	457	606	755
3200	300	536	708	880
3600	344	616	808	1000
4000	388	696	911	1126
4400	433	777	1015	1253
4800	478	859	1118	1377

### PARAMETERS

Convector	Width	170, 320, 360, 420 mm
	Height	115 mm
	Length	800-4800 mm in step 400 mm
	Height adjusting	0-35 mm
	Stainless trough width	150, 300, 360, 420 mm
	Grill type	cross / linear
Exchanger	Grill material	anodized aluminium, wood, stainless steel
	Width	1x, 2x, 3x, 4x Ø 65 mm
	Height	
	Finned length	L320 mm
	Heat medium connection	2 x G1/2" inner
Operating conditions	Max. working temperature	110 °C
	Max. working over-pressure	1 MPa
	Ambient temperature	+2 to +40 °C
	Relative humidity	20-70 %

## FLK10-14 | NATURAL CONVECTION

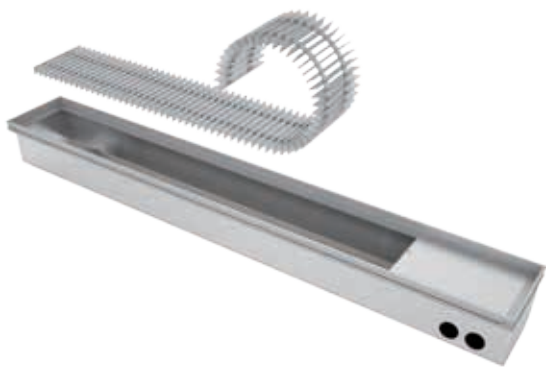

### SPECIFICATIONS

- Width 170 mm
- Offices, corridors, halls, flats, winter garden
- High heating output of natural convection
- Suitable for combining with other heating systems
- Cu-Cu wire heat exchanger
- Mechanical resistance of the heat exchanger
- Easy cleaning - hygiene
- Using in dry ambience

## FLK20-14 | NATURAL CONVECTION



### SPECIFICATIONS

- Width 320 mm
- Offices, corridors, halls, flats, winter garden
- High heating output of natural convection
- Suitable for combining with other heating systems
- Cu-Cu wire heat exchanger
- Mechanical resistance of the heat exchanger
- Easy cleaning - hygiene
- Using in dry ambience

## FLK30-14 | NATURAL CONVECTION



### SPECIFICATIONS

- Width 360 mm
- Offices, corridors, halls, flats, winter garden
- High heating output of natural convection
- Suitable for combining with other heating systems
- Cu-Cu wire heat exchanger
- Mechanical resistance of the heat exchanger
- Easy cleaning - hygiene
- Using in dry ambience

## FLK40-14 | NATURAL CONVECTION



### SPECIFICATIONS

- Width 420 mm
- Offices, corridors, halls, flats, winter garden
- High heating output of natural convection
- Suitable for combining with other heating systems
- Cu-Cu wire heat exchanger
- Mechanical resistance of the heat exchanger
- Easy cleaning - hygiene
- Using in dry ambience

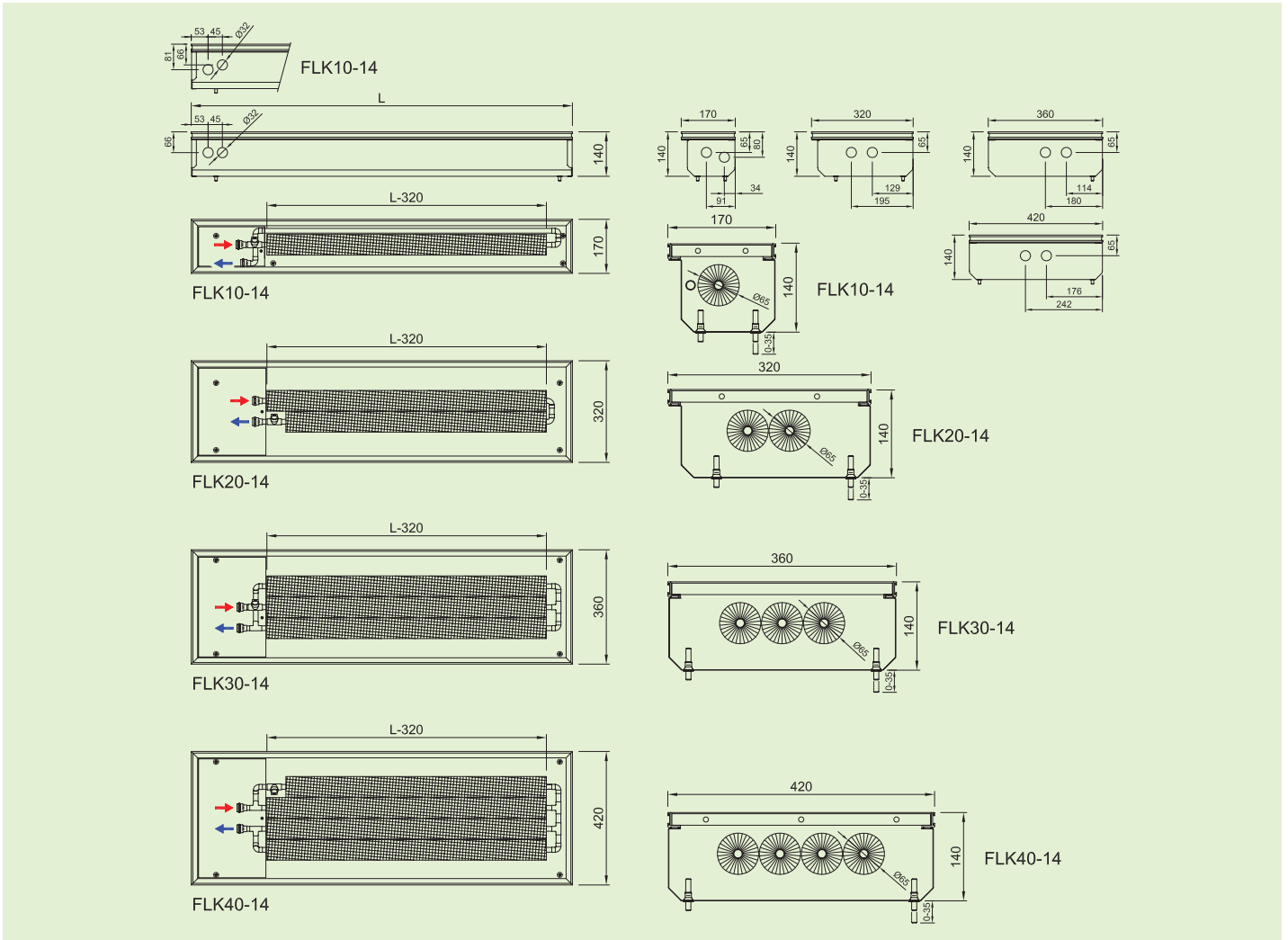

### HEATING OUTPUT

Q [W] 90/70/20°C

TYPE	FLK10-14	FLK20-14	FLK30-14	FLK40-14
LENGTH [mm]	HEATING OUTPUT [W]			
800	144	266	393	489
1200	264	493	704	860
1600	388	727	1025	1243
2000	515	970	1357	1638
2400	644	1215	1691	2036
2800	773	1465	2022	2422
3200	905	1718	2363	2824
3600	1037	1974	2697	3211
4000	1171	2233	3041	3614
4400	1305	2493	3387	4018
4800	1440	2756	3734	4423

Qn [W] 75/65/20°C

TYPE	FLK10-14	FLK20-14	FLK30-14	FLK40-14
LENGTH [mm]	HEATING OUTPUT [W]			
800	117	215	317	394
1200	213	399	568	694
1600	313	589	828	1003
2000	416	784	1096	1323
2400	519	983	1367	1645
2800	624	1185	1635	1959
3200	730	1390	1910	2282
3600	837	1597	2181	2596
4000	945	1806	2460	2922
4400	1053	2017	2739	3250
4800	1162	2229	3019	3576

Q [W] 70/55/20°C

TYPE	FLK10-14	FLK20-14	FLK30-14	FLK40-14
LENGTH [mm]	HEATING OUTPUT [W]			
800	92	170	250	311
1200	168	315	449	548
1600	247	465	654	792
2000	329	619	866	1045
2400	410	777	1080	1300
2800	493	936	1292	1548
3200	577	1098	1509	1803
3600	661	1262	1723	2051
4000	747	1427	1944	2309
4400	832	1594	2164	2568
4800	918	1761	2385	2825

Q [W] 55/45/20°C

TYPE	FLK10-14	FLK20-14	FLK30-14	FLK40-14
LENGTH [mm]	HEATING OUTPUT [W]			
800	55	104	152	188
1200	101	190	272	332
1600	148	281	396	479
2000	196	375	523	631
2400	244	469	652	784
2800	294	566	781	936
3200	345	664	913	1091
3600	395	763	1042	1240
4000	446	863	1175	1396
4400	497	963	1309	1553
4800	549	1065	1442	1707

### PARAMETERS

Convector	Width	170, 320, 360, 420 mm
	Height	140 mm
	Length	800-4800 mm in step 400 mm
	Height adjusting	0-35 mm
	Stainless trough width	150, 300, 360, 420 mm
	Grill type	cross / linear
Exchanger	Grill material	anodized aluminium, wood, stainless steel
	Width	1x, 2x, 3x, 4x Ø 65 mm
	Height	
	Finned length	L320 mm
	Heat medium connection	2 × G1/2" inner
Operating conditions	Max. working temperature	110 °C
	Max. working over-pressure	1 MPa
	Ambient temperature	+2 to +40 °C
	Relative humidity	20-70 %



## FLK20-18 | NATURAL CONVECTION



### SPECIFICATIONS

- Width 300 mm
- Possibility of inner construction A or B
- Installation to the double floor
- Administrative buildings, offices
- High heating output of natural convection
- Cu-Cu wire heat exchanger
- Mechanical resistance of the heat exchanger
- Easy cleaning - hygiene
- Using in dry ambience

## FLK30-18 | NATURAL CONVECTION



### SPECIFICATIONS

- Width 360 mm
- Possibility of inner construction A or B
- Installation to the double floor
- Administrative buildings, offices
- High heating output of natural convection
- Cu-Cu wire heat exchanger
- Mechanical resistance of the heat exchanger
- Easy cleaning - hygiene
- Using in dry ambience

## FLK20-30 | NATURAL CONVECTION



### SPECIFICATIONS

- Width 300 mm
- Possibility of inner construction A or B
- Installation to the double floor
- Administrative buildings, offices
- High heating output of natural convection
- Cu-Cu wire heat exchanger
- Mechanical resistance of the heat exchanger
- Easy cleaning - hygiene
- Using in dry ambience

## FLK30-30 | NATURAL CONVECTION



### SPECIFICATIONS

- Width 360 mm
- Possibility of inner construction A or B
- Installation to the double floor
- Administrative buildings, offices
- High heating output of natural convection
- Cu-Cu wire heat exchanger
- Mechanical resistance of the heat exchanger
- Easy cleaning - hygiene
- Using in dry ambience

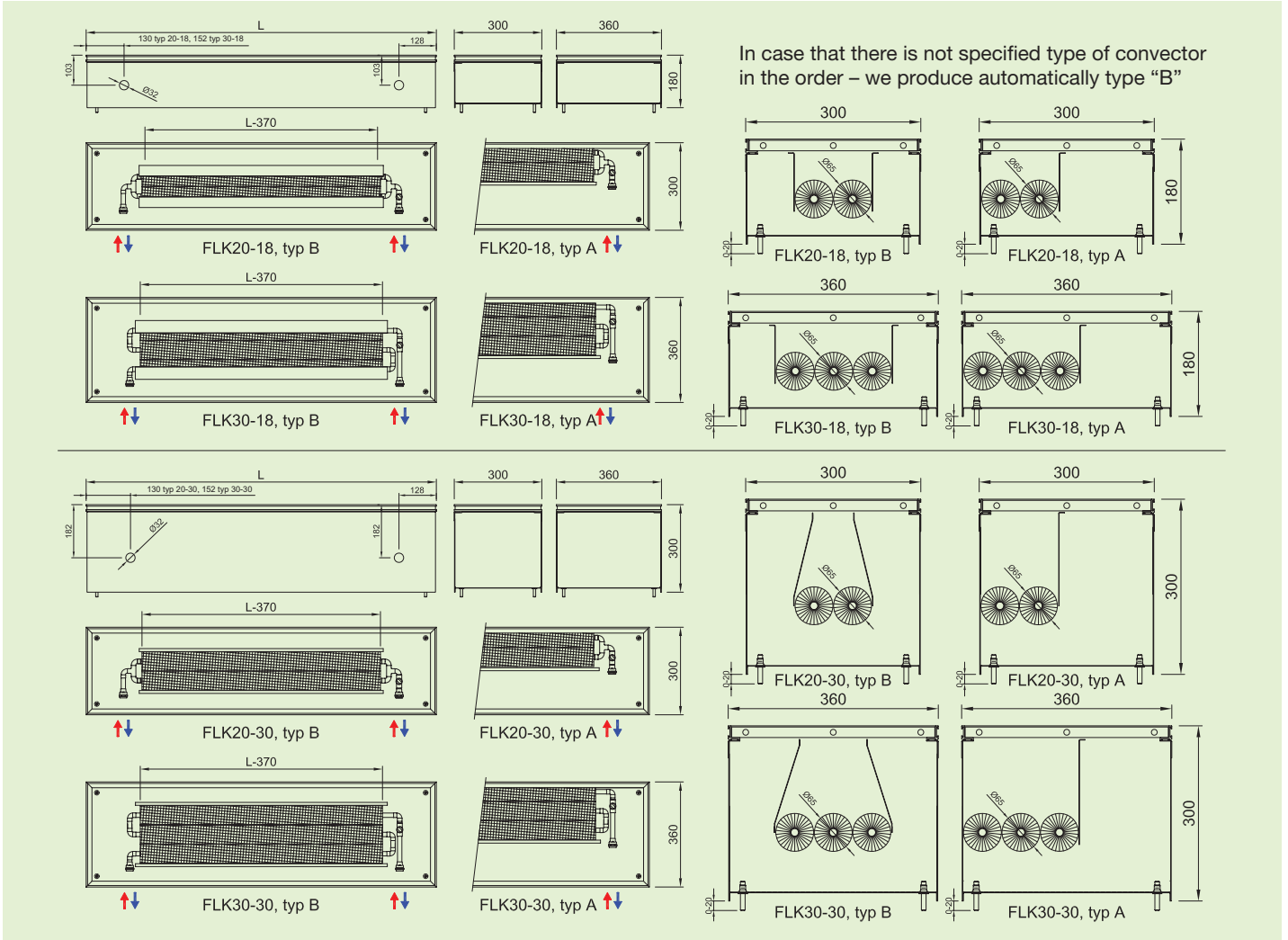

## HEATING OUTPUT

Q [W] 90/70/20°C

TYPE	FLK20-18	FLK30-18	FLK20-30	FLK30-30
LENGTH [mm]	HEATING OUTPUT [W]			
800	333	381	379	550
1200	661	754	752	1090
1600	995	1135	1132	1641
2000	1309	1494	1489	2159
2400	1643	1875	1869	2710
2800	1970	2248	2241	3250
3200	2304	2629	2621	3801
3600	2618	2988	2978	4319
4000	2952	3369	3358	4870
4400	3286	3750	3738	5421
4800	3613	4123	4110	5961

Qn [W] 75/65/20°C

TYPE	FLK20-18	FLK30-18	FLK20-30	FLK30-30
LENGTH [mm]	HEATING OUTPUT [W]			
800	257	293	289	419
1200	510	582	573	831
1600	767	875	862	1250
2000	1009	1152	1134	1645
2400	1267	1446	1423	2065
2800	1519	1734	1707	2476
3200	1777	2028	1996	2896
3600	2019	2304	2269	3290
4000	2277	2598	2558	3710
4400	2534	2892	2847	4130
4800	2787	3180	3131	4541

Q [W] 70/55/20°C

TYPE	FLK20-18	FLK30-18	FLK20-30	FLK30-30
LENGTH [mm]	HEATING OUTPUT [W]			
800	204	233	227	329
1200	405	462	450	652
1600	609	695	677	981
2000	801	915	890	1291
2400	1006	1148	1117	1621
2800	1206	1377	1340	1944
3200	1411	1610	1567	2273
3600	1603	1829	1781	2582
4000	1808	2063	2008	2912
4400	2012	2296	2235	3242
4800	2213	2525	2458	3564

Q [W] 55/45/20°C

TYPE	FLK20-18	FLK30-18	FLK20-30	FLK30-30
LENGTH [mm]	HEATING OUTPUT [W]			
800	124	142	135	195
1200	246	281	267	387
1600	370	423	402	583
2000	487	556	529	767
2400	612	698	664	963
2800	734	837	796	1155
3200	858	979	931	1351
3600	975	1113	1058	1535
4000	1100	1255	1193	1731
4400	1224	1397	1328	1926
4800	1346	1536	1460	2118

## PARAMETERS

Convector	Width	300, 360 mm
	Height	180, 300 mm
	Length	800-4800 mm in step 400 mm
	Height adjusting	0-20 mm
	Stainless trough width	300, 360 mm
	Grill type	cross / linear
Exchanger	Grill material	anodized aluminium, wood, stainless steel
	Width	2x, 3x Ø 65 mm
	Height	2x, 3x Ø 65 mm
	Finned length	L-370 mm
	Heat medium connection	2 x G1/2" inner
Operating conditions	Max. working temperature	110 °C
	Max. working over-pressure	1 MPa
	Ambient temperature	+2 to +40 °C
	Relative humidity	20-70 %